

INSTRUCTION MANUAL

TM-33170HDX

Heavy Duty Centre Lathe - BIG BORE (415V) 860 x 4310mm - 153mm Bore

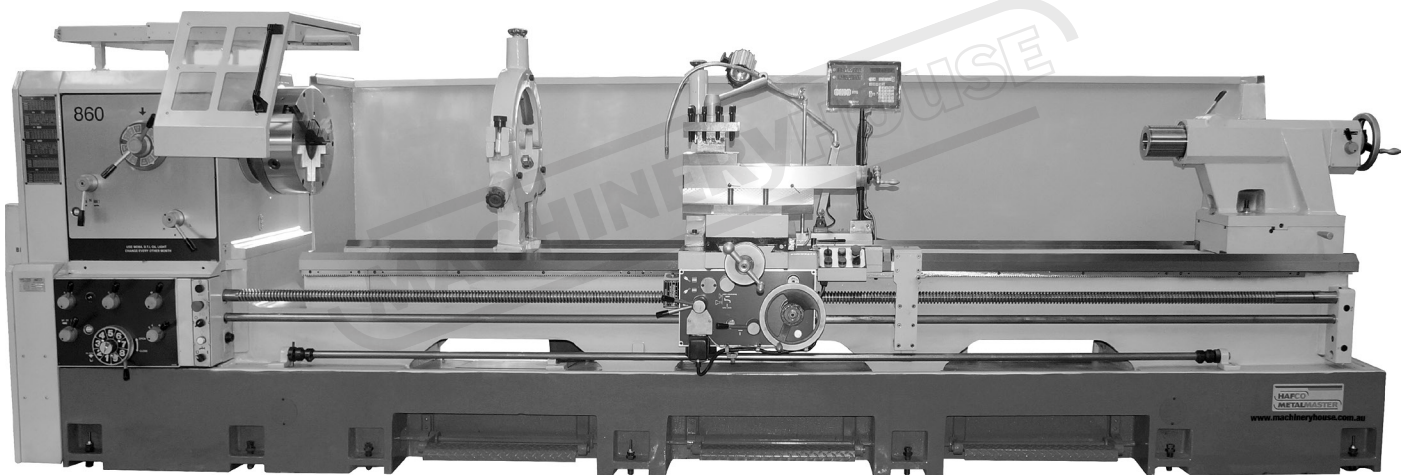

L646D



WARNING

General Machinery Safety Instructions

Machinery House
requires you to read this entire Manual before using this machine.

- 1. Read the entire Manual before starting machinery.** Machinery may cause serious injury if not correctly used.
- 2. Always use correct hearing protection when operating machinery.** Machinery noise may cause permanent hearing damage.
- 3. Machinery must never be used when tired, or under the influence of drugs or alcohol.** When running machinery you must be alert at all times.
- 4. Wear correct Clothing.** At all times remove all loose clothing, necklaces, rings, jewelry, etc. Long hair must be contained in a hair net. Non-slip protective footwear must be worn.
- 5. Always wear correct respirators around fumes or dust when operating machinery.** Machinery fumes & dust can cause serious respiratory illness. Dust extractors must be used where applicable.
- 6. Always wear correct safety glasses.** When machining you must use the correct eye protection to prevent injuring your eyes.
- 7. Keep work clean and make sure you have good lighting.** Cluttered and dark shadows may cause accidents.
- 8. Personnel must be properly trained or well supervised when operating machinery.** Make sure you have clear and safe understanding of the machine you are operating.
- 9. Keep children and visitors away.** Make sure children and visitors are at a safe distance for you work area.
- 10. Keep your workshop childproof.** Use padlocks, Turn off master power switches and remove start switch keys.
- 11. Never leave machine unattended.** Turn power off and wait till machine has come to a complete stop before leaving the machine unattended.
- 12. Make a safe working environment.** Do not use machine in a damp, wet area, or where flammable or noxious fumes may exist.
- 13. Disconnect main power before service machine.** Make sure power switch is in the off position before re-connecting.
- 14. Use correct amperage extension cords.** Undersized extension cords overheat and lose power. Replace extension cords if they become damaged.
- 15. Keep machine well maintained.** Keep blades sharp and clean for best and safest performance. Follow instructions when lubricating and changing accessories.
- 16. Keep machine well guarded.** Make sure guards on machine are in place and are all working correctly.
- 17. Do not overreach.** Keep proper footing and balance at all times.
- 18. Secure workpiece.** Use clamps or a vice to hold the workpiece where practical. Keeping the workpiece secure will free up your hand to operate the machine and will protect hand from injury.
- 19. Check machine over before operating.** Check machine for damaged parts, loose bolts, Keys and wrenches left on machine and any other conditions that may effect the machines operation. Repair and replace damaged parts.
- 20. Use recommended accessories.** Refer to instruction manual or ask correct service officer when using accessories. The use of improper accessories may cause the risk of injury.
- 21. Do not force machinery.** Work at the speed and capacity at which the machine or accessory was designed.
- 22. Use correct lifting practice.** Always use the correct lifting methods when using machinery. Incorrect lifting methods can cause serious injury.
- 23. Lock mobile bases.** Make sure any mobile bases are locked before using machine.
- 24. Allergic reactions.** Certain metal shavings and cutting fluids may cause an allergic reaction in people and animals, especially when cutting as the fumes can be inhaled. Make sure you know what type of metal and cutting fluid you will be exposed to and how to avoid contamination.
- 25. Call for help.** If at any time you experience difficulties, stop the machine and call you nearest branch service department for help.



WARNING

Metal Lathe Safety Instructions

Machinery House
requires you to read this entire Manual before using this machine.

- 1. Maintenance.** Make sure the lathe is turned off and disconnect from the main power supply and make sure all moving parts have come to a complete stop before any inspection, adjustment or maintenance is carried out.
- 2. Lathe Condition.** Lathe must be maintained for a proper working condition. Never operate a lathe that has damaged or worn parts. Scheduled routine maintenance should be performed on a scheduled basis.
- 3. Leaving a Lathe Unattended.** Always shut the lathe off and make sure all moving parts have come to a complete stop before leaving the lathe. An unsupervised running lathe can cause serious injury.
- 4. Avoiding Entanglement.** Remove loose clothing, belts, or jewelry items. Tie up long hair and use the correct hair nets to avoid any entanglement with moving parts.
- 5. Chuck key safety.** Never let go of a chuck key while still in the chuck to prevent leaving the chuck key in the chuck. Chuck keys left in the chuck can cause serious injury.
- 6. Changing Chucks.** When changing large heavy chucks they become awkward to hold. Always get assistance when installing large chucks. Use a board or piece of plywood across the bedway when any install or removal of chucks to avoid any possible finger pinching between a loose chuck and edge of a bedway.
- 7. Tooling selection.** Always use the correct cutting tool for the job you are turning. Make sure it is sharp and held firmly in the tool post. Adjust the toolpost to provide proper support for the tool you will be using.
- 8. Mounting the workpiece.** Make sure the workpiece is properly mounted and secure before turning on the lathe. A loose workpiece can be thrown across the room and cause serious injury to you or a bystander.
- 9. Workpiece clearance.** Rotate the workpiece by hand to check for clearance with the tool post, compound slide and carriage before turning the lathe on.
- 10. Changing speeds and Reversing.** Turn the lathe off and make sure the lathe has come to a complete stop before changing speeds or reversing the spindle. Do not slow or stop the lathe chuck by using your hand.
- 11. Speed selection.** Select the appropriate speed for the type of work, material, and tool bit. Allow the lathe to reach full speed before beginning a cut.
- 12. Clearing chips.** Always use a brush to clear chips. Never clear chips when the lathe is running.
- 13. Power outage.** In the event of a power failure during use of the lathe, turn off all switches to avoid possible sudden start up once power is restored.
- 14. Clean work area.** Keep the area around the lathe clean from oil, tools and chips.
- 15. Call for help.** If at any time you experience difficulties, stop the machine and call your nearest branch service department for help.

PLANT SAFETY PROGRAM

NEW MACHINERY HAZARD IDENTIFICATION, ASSESSMENT & CONTROL

Metal Lathe

Developed in Co-operation Between A.W.I.S.A and Australia Chamber of Manufactures
This program is based upon the Safe Work Australia, Code of Practice - Managing Risks of Plant in the Workplace (WHSA 2011 No10)

Item No.	Hazard Identification	Hazard Assessment	Risk Control Strategies <small>(Recommended for Purchase / Buyer / User)</small>
A	ENTANGLEMENT	HIGH	Eliminate, avoid loose clothing / Long hair etc.
C	CUTTING, STABBING, PUNCTURING	MEDIUM	Isolate power to machine prior to any checks or maintenance. Do not open or clean inside until the machine has completely stopped.
D	SHEARING	MEDIUM	Make sure all guards are secured shut when machine is on. Isolate power to machine prior to any checks or maintenance.
F	STRIKING	MEDIUM	Ensure workpiece is secured in chuck and tooling is locked tight in toolpost. Always wear safety glasses. Do not leave chuck key in chuck. Remove all loose objects around moving parts.
H	ELECTRICAL	MEDIUM	All electrical enclosures should only be opened with a tool that is not to be kept with the machine.
N	HIGH - TEMPERATURE	LOW	Machine should be installed & checked by a Licensed Electrician.
O	OTHER HAZARDS, NOISE.	LOW	Wear appropriate protective clothing to prevent hot swarf. Wear hearing protection as required.
Plant Safety Program to be read in conjunction with manufactures instructions			



www.machineryhouse.com.au



www.machineryhouse.co.nz

Authorised and signed by:
Safety officer:



Manager:



Revised Date: 12th March 2012

HEAVY DUTY PRECISION LATHE

OPERATION MANUAL

X33

X37

X41

MACHINERYHOUSE

HIGH SPEED PRECISION LATHE

OPERATION MANUAL

CONTENTS**PREFACE****1. Machine Assembly****2. ELECTRICAL CIRCUIT CONTROL**

2-1 Electrical Wiring

2-2 Electrical Equipment

2-3 Electrical Cautions

2-4 Circuit Diagram

2-5 Operation Symbols

3. UNPACKING & MACHINE INSTALLATION

3-1 Unpacking & Lifting

3-2 Basic Foundation

4. MAJOR CONSTRUCTION

4-1 Headstock

4-2 Spindle

4-3 Spindle Speed Selection

4-4 Slide

4-5 Tailstock

4-6 Apron

4-7 Gear Box

4-8 Thread indicator

4-9 Steady rest

4-10 Brake system

5. LUBRICATION

5-1 Headstock Lubrication

5-2 Gear Box & Apron Lubrication

5-3 Lubrication Charts

5-4 Lubrication Location

HIGH SPEED PRECISION LATHE

OPERATION MANUAL

CONTENTS

6. MAINTENANCE & ADJUSTMENT

6-1 Headstock

6-2 Apron & Saddle

6-3 Gear box

6-4 Belt Tension Adjustment

6-5 Brake Belt Adjustment

6-6 Brake & Micro Switch Adjustment

6-7 Cutting Coolant Repair

7. PART LISTS

MACHINERYHOUSE

PREFACE

Thank you for adopting our lathe to be your producing tool. Before operating the lathe, it is necessary to study our manual. If operated correctly, the machine is efficient and easy-to-operate.

This manual consists of 12 chapters, mainly including operation, maintenance and list of spare parts. Please read the manual thoroughly from the first page to the last in order to be familiar with this machine, and work efficiently and accurately. Besides, based on safety consideration, the operator must be well trained according to all the instructions in the manual. Any damage of the machine and injure on the operator caused by mis-operation and disregard of our instruction is not under warranty.

In addition to the instructions listed in our manual, there are some matters needing attention as well:

1. Do not expose the machine outdoors in order to avoid any damage caused by the weather, besides, keep the machine away from cooling blower.
2. Lubricate the machine with recommended or appointed lubricant or grease.
3. Remove chips from time to time to keep the machine clean, this will make the machine live longer.
4. If the bed way is dented, do not move the carriage till the bed way is repaired.

1. Machine Assembly

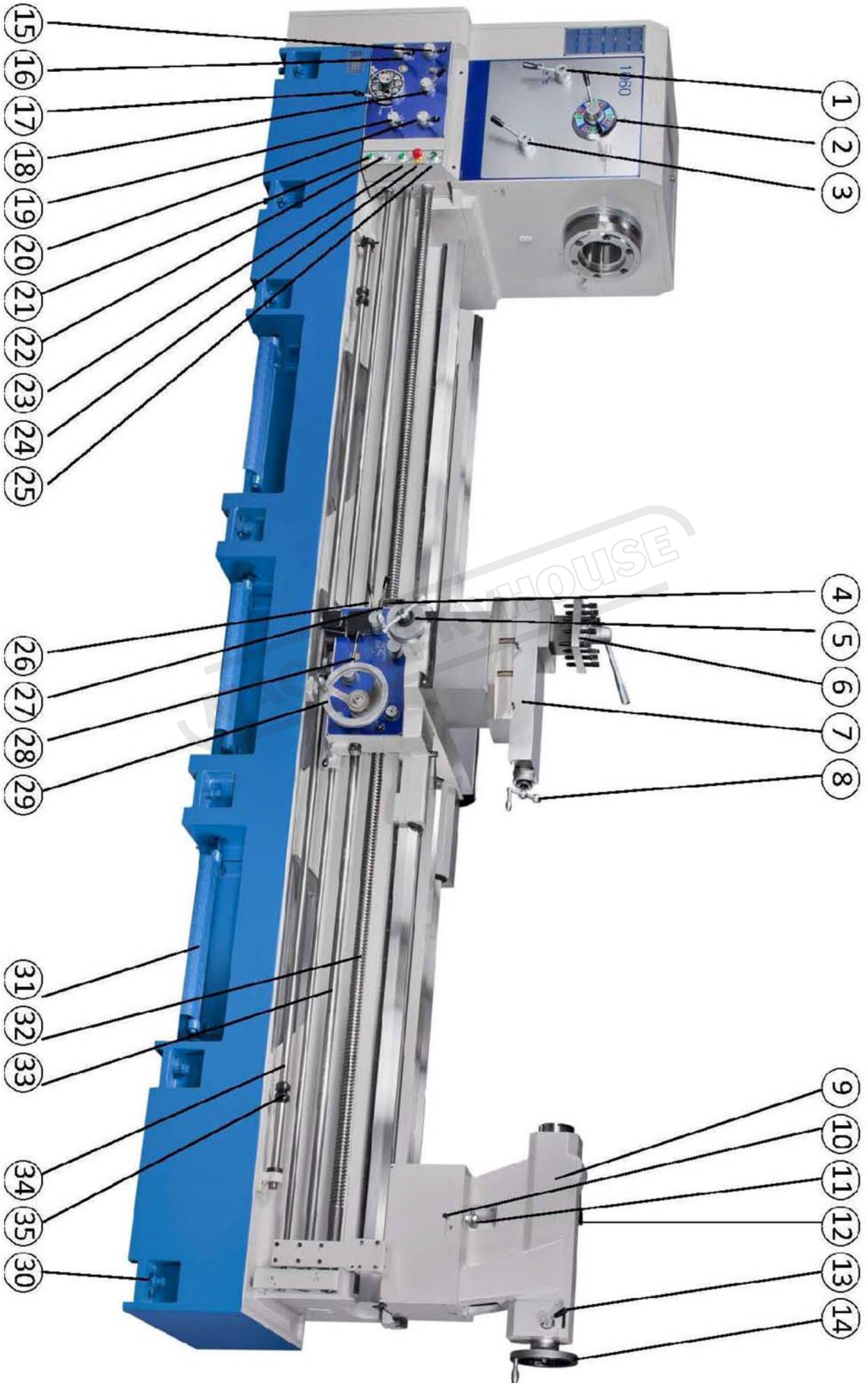

Fig. 1-1

ITEM	DESCRIPTION	ITEM	DESCRIPTION
1	Forward/Reverse Shifting lever	19	4 steps feed selection dial
2	Spindle speed shifting selection lever	20	Spindle speed W.M shifting lever
3	Spindle speed H/M/N/L shifting lever	21	Coolant control switch
4	Thread dial indicator	22	Power indicator
5	Cross feeding Handel	23	Power switch (Main switch)
6	4 way tool post holder	24	Emergency stop
7	Compound rest	25	Intermittent button
8	Compound rest handle	26	Half nut engaged lever
9	Tailstock body	27	Longitudinal feed hand wheel
10	Tailstock set over adjusting Screw	28	Auto feeding engaged lever
11	Tailstock body Clamping lever	29	Apron hand-wheel
12	Tailstock spindle locking lever	30	Foundation adjusting bolt
13	Spindle speed shifting lever	31	Foot brake pedal
14	Tailstock hand wheel	32	Lead screw
15	Spindle speed A.B shifting lever	33	Auto-feed rod
16	MP&DP thread operate lever	34	Auto feed stop selection rod
17	9 steps feed selection dial	35	Adjustable trip dog
18	Spindle speed C.D shifting lever		

2. ELECTRICAL CIRCUIT CONTROL

2-1 Electrical Wiring

1. The electrical control box can be found by opening its cover at the back side of bed. Connect the power source wire with the connecting points (R.S.T)

The wire between the power source and the connecting points must be over sectional area 8mm^2 (5.5mm^2 for 480 or 19" series).

2. The main switch between machine and power source also should be equipped with safety fuse. Besides, the machine must have a earth wire.



Fig. 2-1

2-2 Electrical Equipment

1. The electrical control box is also equipped with overload circuit breaker and electric magnetic contactor to protect motor from burning out by overload.
2. The forward/reverse switch is connected with micro switch.
3. The foot brake is connected with micro switch. Stepping the footbrake is quicker to stop the lathe than turning off the switch. The spindle can only revolute again by re-operating the spindle operation control lever after using the foot brake.
4. The spindle will rotate continuously as long as the intermittent switch on the top of the electrical control box is pressed.

2-3 Electrical Cautions

1. After wiring, check the rotation of the spindle of the spindle. Turn the main switch “ON” and make sure the safety of spindle. Then push intermittent button (T) momentarily. The correction direction of the spindle rotation is counter clockwise. (looking from tailstock for a downward movement of the spindle operation control lever.) Wrong direction of rotation can be rectified by interchanging any two of the three phase lines (R.S.T.) in the power source.
2. Checking each lubrication system with oil.
3. Checking each handle with normal function.
4. Checking belt Tension Adjustment in good condition.
5. Read and understand for each constructor well before operation.
6. When power indicator “ON”, overload circuit breaker and electric magnetic contactor to protect motor from burning out by overload, please reset the circuit breaker by press the recover plate and lathe will resume to available. (The electric wiring attached at chapter 2-4)

MACHINERYHOUSE

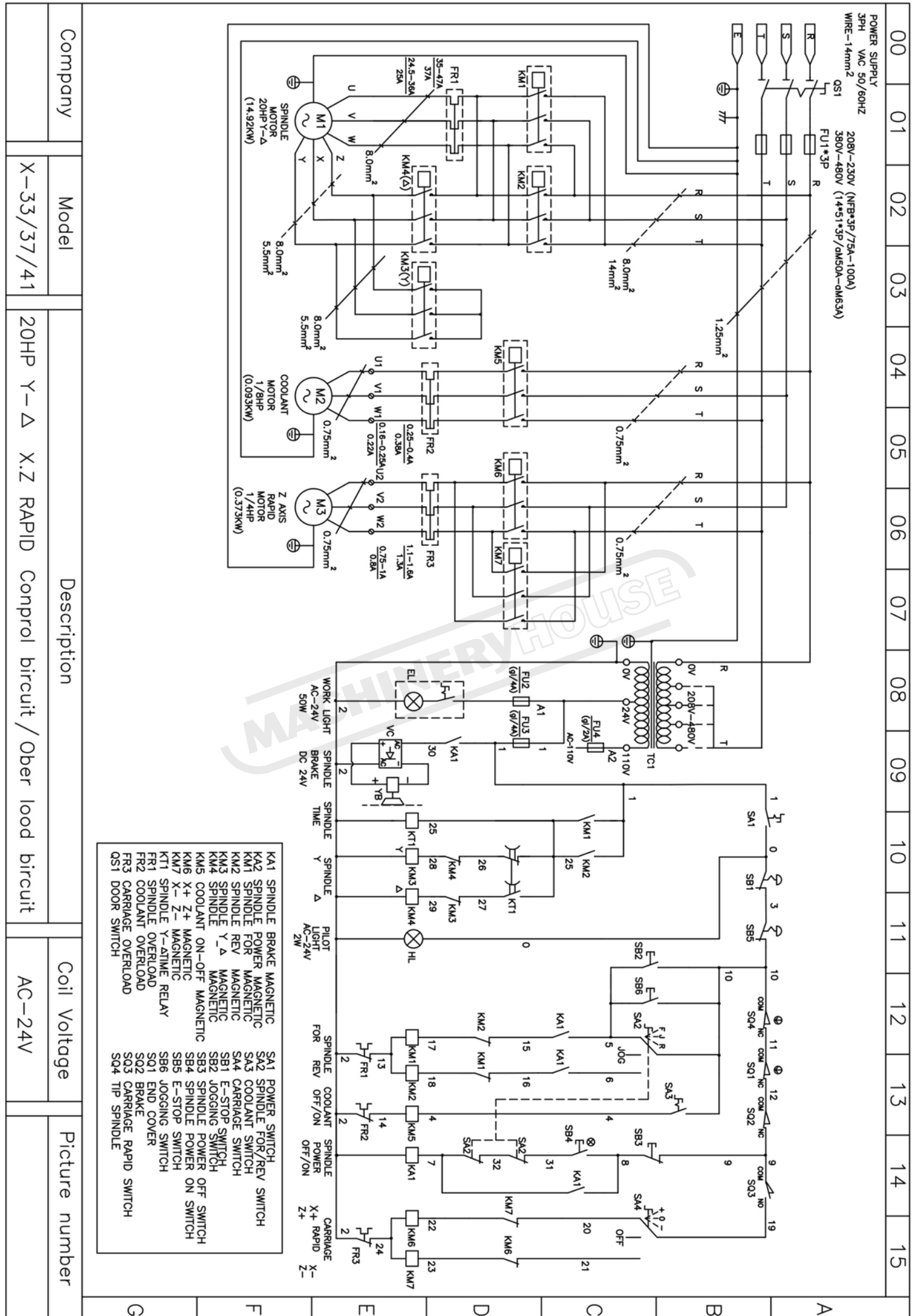

















00 01 02 03 04 05 06 07 08 09 10 11 12 13 14 15

- KA1 SPINDLE BRAKE MAGNETIC
- KA2 SPINDLE FOR MAGNETIC
- KA1 SPINDLE FOR MAGNETIC
- KA1 SPINDLE REV MAGNETIC
- KA2 SPINDLE Y_Δ MAGNETIC
- KA3 SPINDLE Y_Δ MAGNETIC
- KA4 COOLANT ON-OFF MAGNETIC
- KA5 COOLANT ON-OFF MAGNETIC
- KA6 X+ Z+ MAGNETIC
- KA7 X- Z- MAGNETIC
- KT1 SPINDLE Y-Δ TIME RELAY
- FR1 SPINDLE OVERLOAD
- FR2 COOLANT OVERLOAD
- FR3 CARRIAGE OVERLOAD
- DS1 DOOR SWITCH
- SA1 POWER SWITCH
- SA2 SPINDLE FOR/REV SWITCH
- SA3 COOLANT SWITCH
- SA4 CARRIAGE SWITCH
- SB1 E-STOP SWITCH
- SB2 JOGGING SWITCH
- SB3 SPINDLE POWER OFF SWITCH
- SB4 SPINDLE POWER ON SWITCH
- SB5 E-STOP SWITCH
- SB6 JOGGING SWITCH
- SQ1 END COVER
- SQ2 BRAKE
- SQ3 CARRIAGE RAPID
- SQ4 TIP SPINDLE

Company	Model	Description	Coil Voltage	Picture number
	X-33/37/41	20HP Y-Δ X.Z RAPID Control bircuit / Ober lood bircuit	AC-24V	

A B C D E F G

2-5 Operation Symbols

1	HIGH	High speed revolution	11		Variable adjustment (pressure) Clockwise: pressure increase Counterclockwise: pressure decrease
2	LOW	Low speed revolution	12		Electrical control box
3		Forward revolution	13		Imperial threads
4		Neutral gear	14		Metric threads
5		Reverse revolution	15		Auto feeding rate per revolution
6		Feeding	16		Pump
7		Intermittent	17		Power switch- ON
8		Cross feeding	18		Power switch-OFF
9		Longitudinal feeding	19	OIL	Oil inlet (hole)
10		Cone clutch			

3. UNPACKING & MACHINE INSTALLATION

3-1 Unpacking & Lifting

When the machine is arrived, first, check if the wooden case is damaged or not, secondly, open the case and inspect the machine for any damage or short supply of parts. If so, please contact our company or insurance company immediately in order to get the best solution or refund; otherwise our company or the insurance company will not be in the position to compensate for the damage.

Please refer to below picture for machine unloading from the truck & moving:

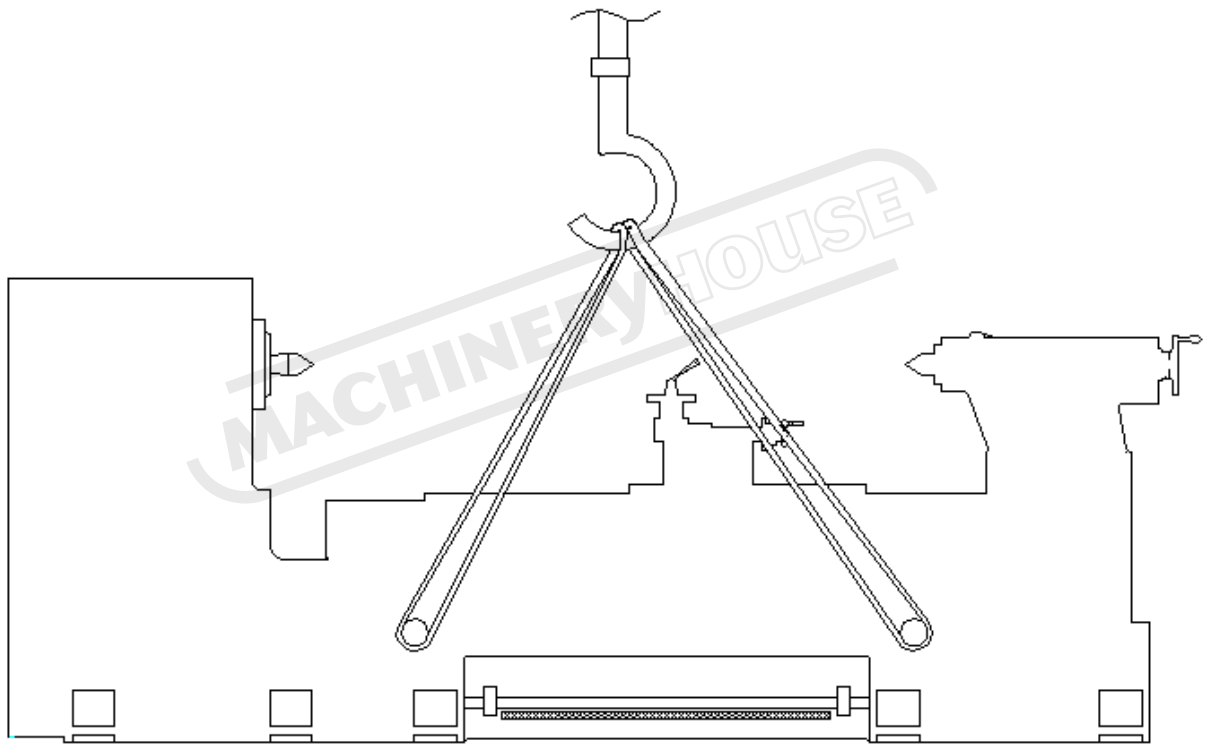

The steps of lifting the lathes are:

- (1) Clamp the bed way with a special made hanger and bars (through the base holes) , which consists of a clamp and an iron chain.
- (2) Raise the lathe a little bit with crane, then check if the lathe is balanced. If not, move apron and cross slide back or forth to make the machine is balanced.
- (3) While the machine arrives at the location, put down the machine slowly to avoid any inaccuracy of the machine caused by bumps or crash.
- (4) For adjusting the electrical cabinet, the machine should be located allowing sufficient area, min. over 600mm from wall at back and tailstock end.

3 - 2 Basic Foundation

With the common usage of tungsten carbide cutting tools nowadays, heavy cutting and quicker spindle speed are therefore reinforced. This may cause the vibration easily. In order to ascertain the best cutting condition it is necessary to build a sound & good floor basic.

Adjust the leveling by adjustable screw and and nut-lock and fix the angled bolt within concrete.

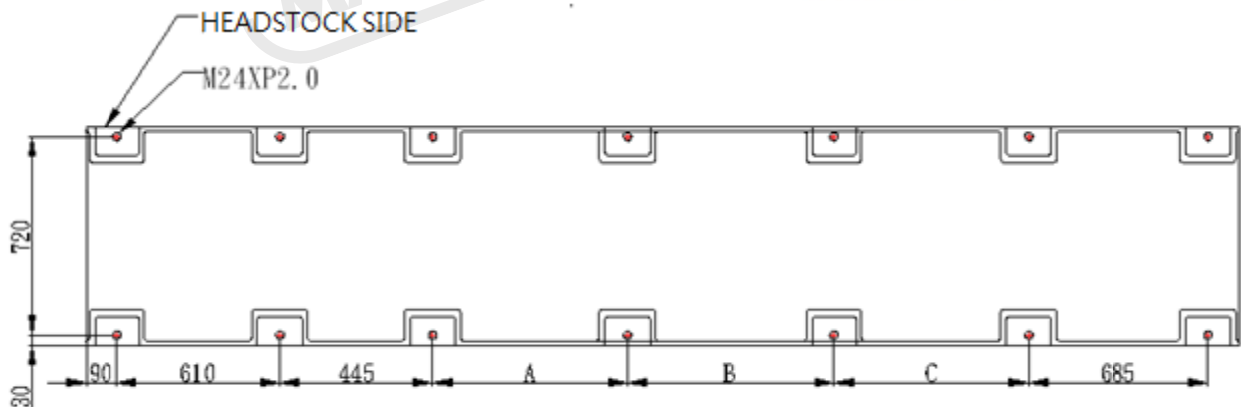
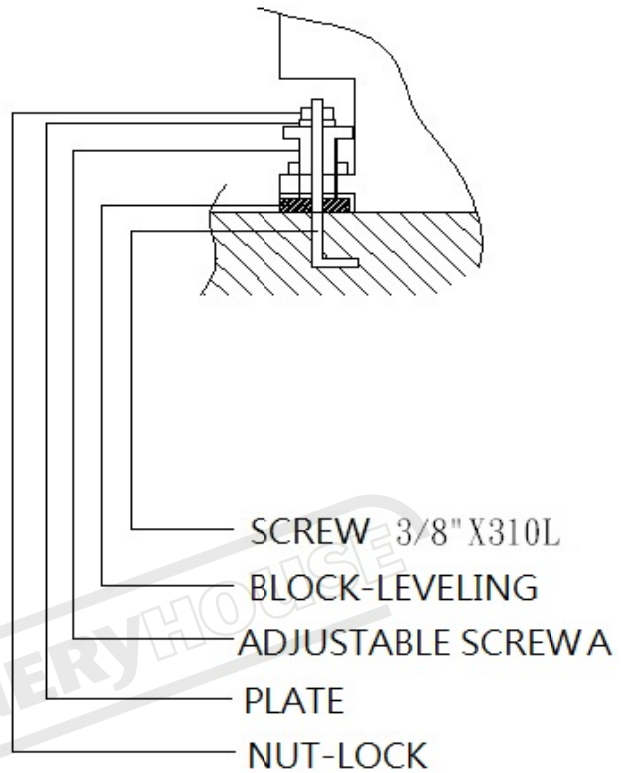

Model	A	BxN	C	Model	A	BxN	C
3370	1430	0	0	33210	965	1000x3	965
3390	965	0	965	33250	965	1000x4	965
33130	965	1000x1	965	33290	965	1000x5	965
33170	965	1000x2	965	33330	965	1000x6	965

4. MAJOR CONSTRUCTION

4-1 HEADSTOCK

1. With high tensile durable cast iron material, which can stand the higher loads, the internal gears are made of chrome molybdenum alloy steel, made after carburizing and quenching treatment and precision grinding, friction, wear-resistant, and low noise.
2. Spindle speed with 12 steps speed change, the device included circular speed plate, three section shift lever, and the shift lever control reversed and forward. Ensure you change the spindle speed after stopping spindle. Otherwise the gears will be damaged. Resulting in noise and vibration of the lathe and reduction of accuracy and life.

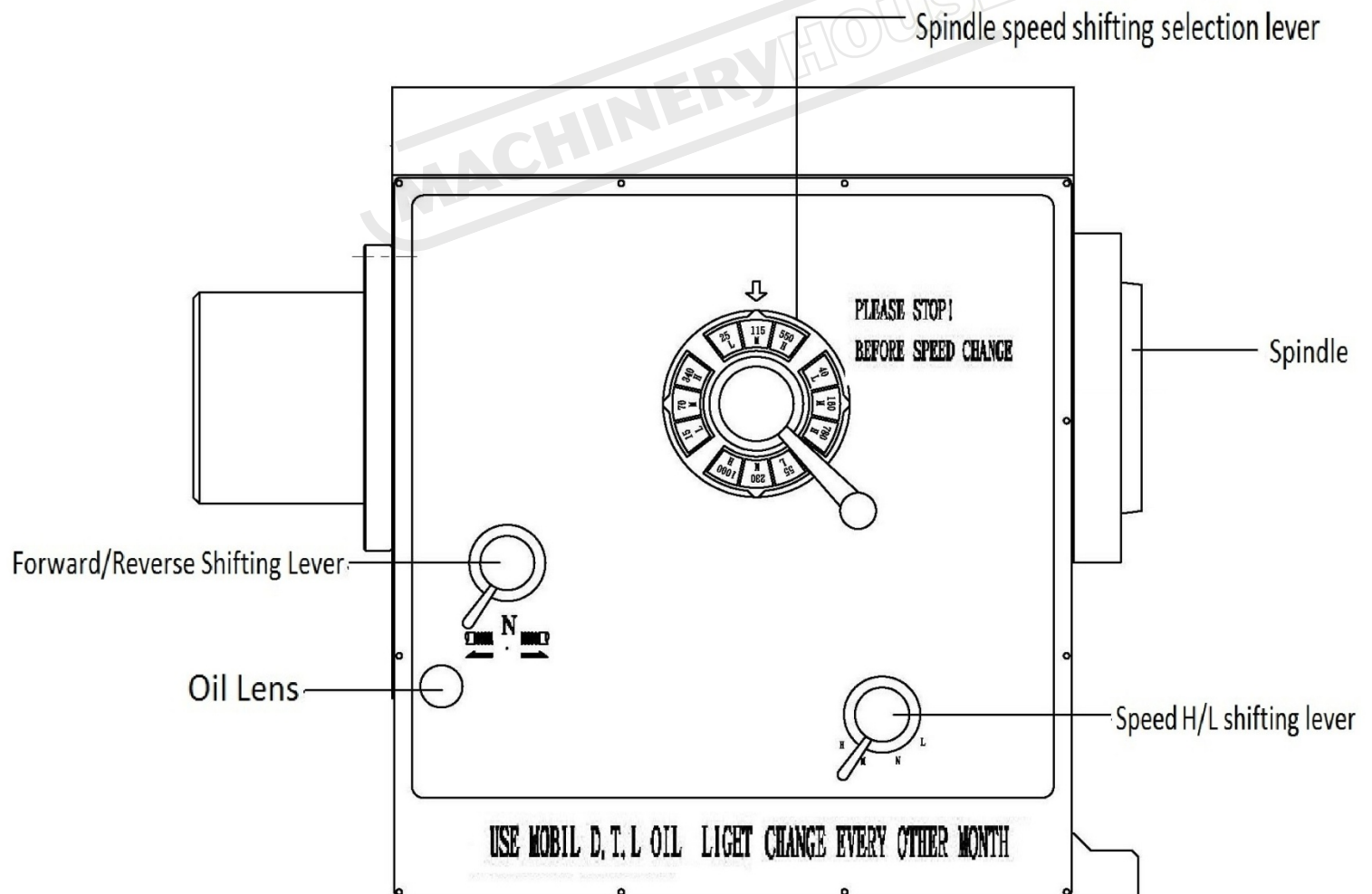

4-2 SPINDLE

1. Entire spindle build by forged, precision cutting and grinding.
2. Spindle design as a three-point support device, the front-end of two ultra-precision taper bearings and back-end using a deep groove ball bearing can withstand heavy-duty and for heavy cutting and precision cutting purposes.
3. To adjust two taper bearing clearance, please loosen the adjustment nut screw first. To adjust it.

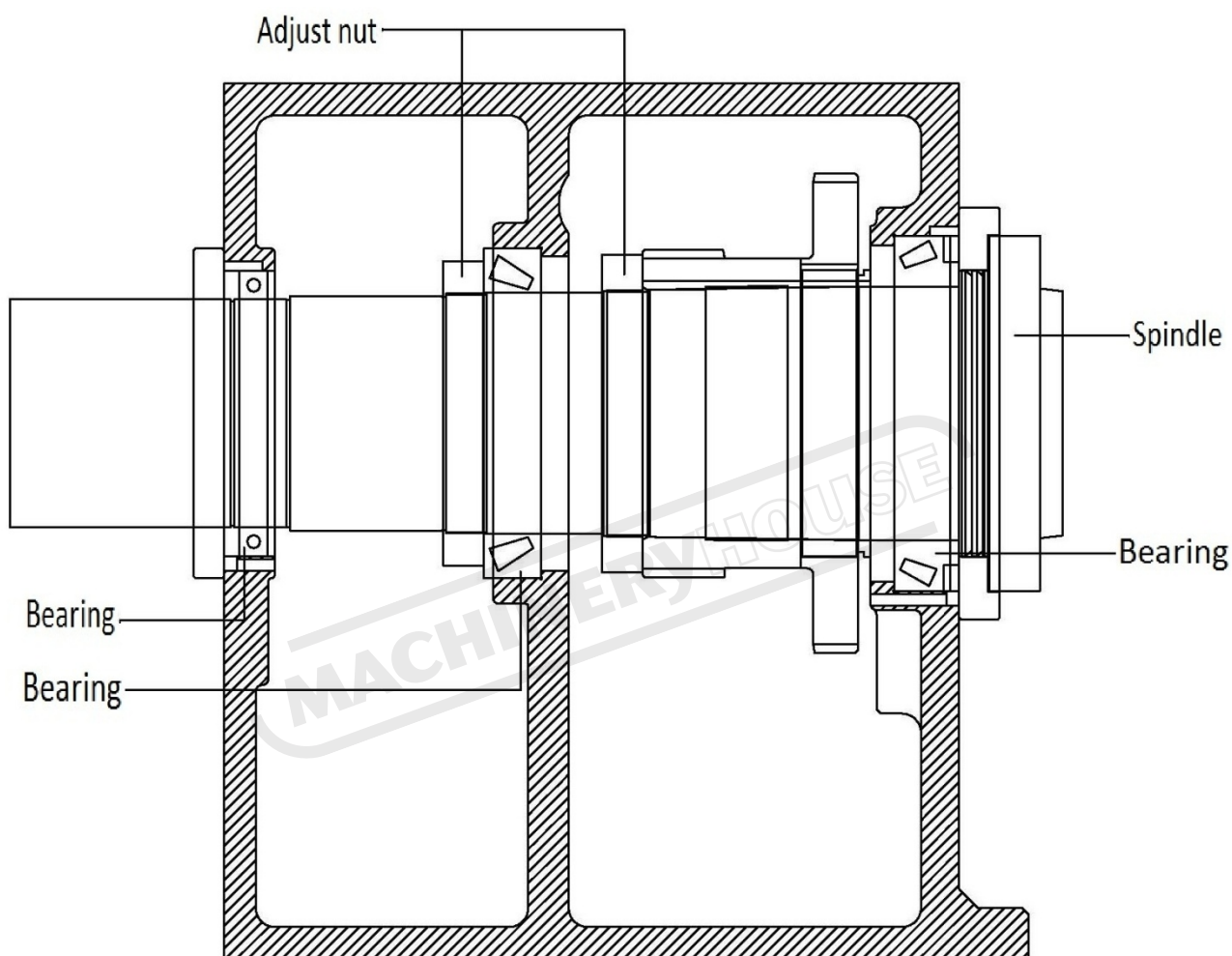

Spindle structure

4-3 Spindle Speed Selection

1. Operation of the spindle speed, please refer to spindle speed table ,
Select the speed range “L”, ”M” or “H”. : To select 680 rpm, first to operate the control shaft to “H” position , and then rotate the shift lever to position to the “680”.
2. To operate the speed lever easier push the intermittent button.

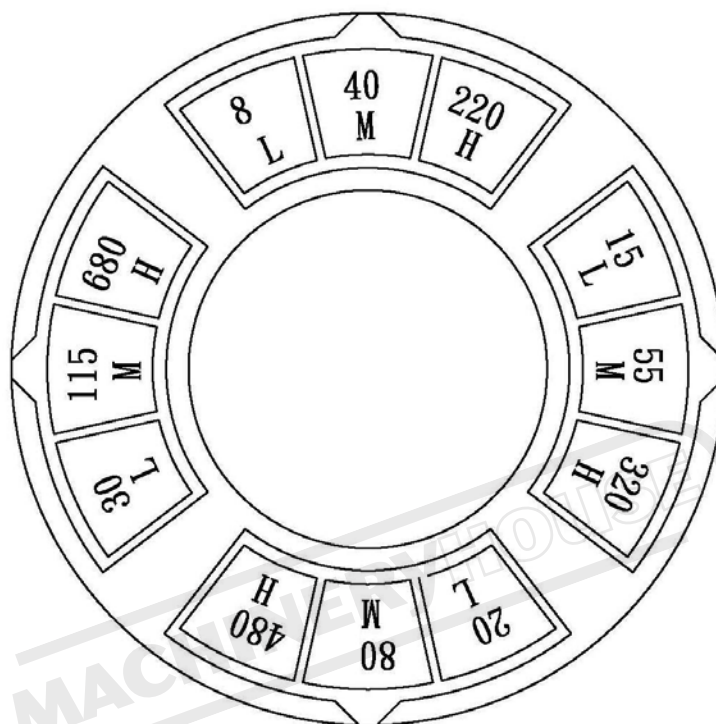

4-4 Slide

- Slide is the saddle-shaped casting on the lathe bed, the main structure are the saddle-shaped slide body, compound slide and the 4-way tool post. Main function of slide is for compound slide and tool holder mounted and fixed tool for cross and longitudinal feed operation.

- Cutting in the longitudinal feed

Cutting in the longitudinal feed, in order to avoid the slide moving backwards, leading to the cutting surface being uneven. It has a locking screw D on the slides.

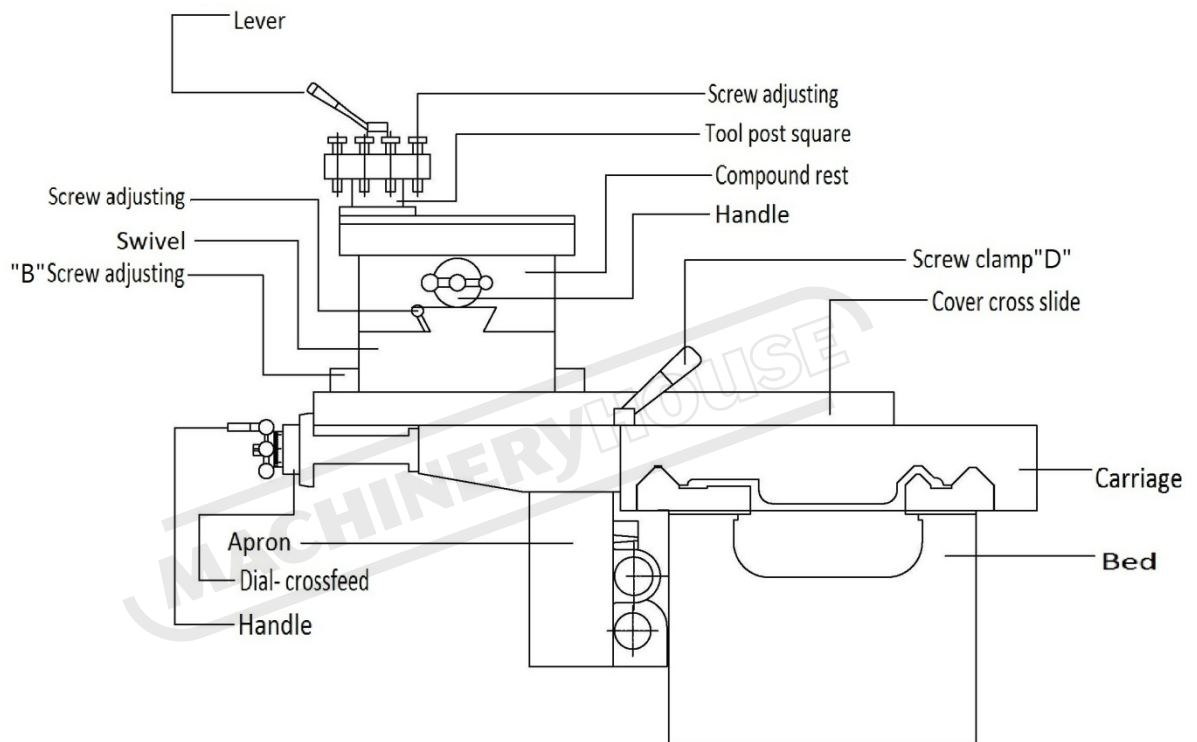

- Slope cutting

Cross carriage inscribed with the mark-indicator, when do the slope cutting, please loosen the locking Screw B, and rotating the compound rest by angle you need, and then fixed it tightly.

- Adjustment of the gibs

To avoid the gap caused by the long period wearing and tearing of sliding surface, a gib for possible adjustments to eliminate the gap in each carriage; To adjust, please loosen the end locking screw and tighten adjustment screw A first, and adjust the wedge to maintain proper clearance, then tighten the screws.

- Indicator The indicator moves forward 10mm revolution, could be divided into 250, 0.04mm per graduation. When reset to zero, please loosen the screw then fix after adjustment.

4-5 Tailstock

1. The main structure of the tailstock: the tailstock body, tailstock base plate, the tailstock sleeve, and speed control box. The tailstock sleeve and spindle are in the same level center position, also support the longitudinal movement on the bed and the spindle support the work material, cutting and drilling of two ends.

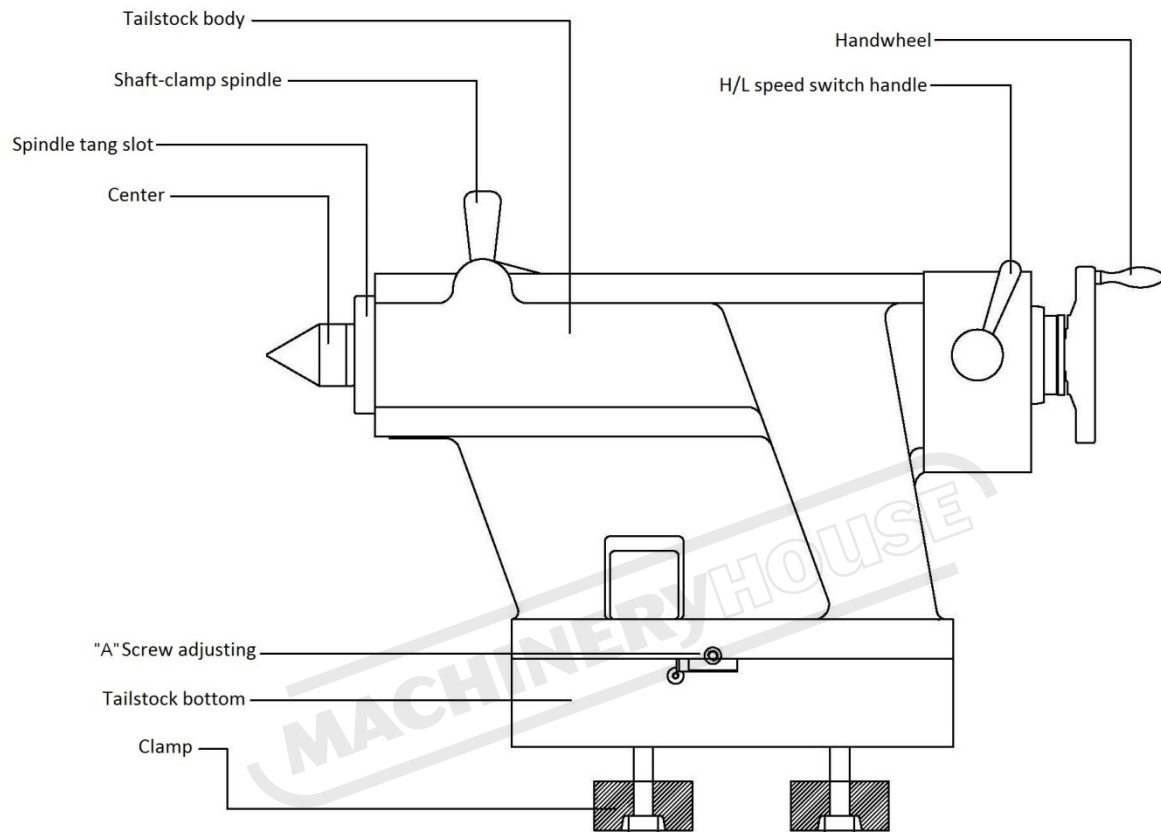

2. Operation

- 2-1. The tailstock hand wheel is located next to the speed control box, please operate transmission shift handle, and then turning the hand wheel tailstock spindle to do 1 to 1 or 1 to 4 fast-slow moving for drilling feed and backward.
- 2-2. Shaft-clamp spindle fixed the tailstock center.
- 2-3. Clamping plate for fix the tailstock tightly on lathe bed.
- 2-4. When the center of tailstock center sleeve and spindle are not on the same level line, please loosen and tight the screw by both adjust screw A. This adjustment is also available on tailstock center and spindle center horizontal adjustment for cutting of between center.

4-6 Apron

1. The main function of the apron is moving backward and forward, the feed slide auto-feeding and thread cutting auto-feeding; the feed device are: thread indicator, the half nut control lever, auto-feeding lever ,tappet, longitudinal feeding hand wheel.

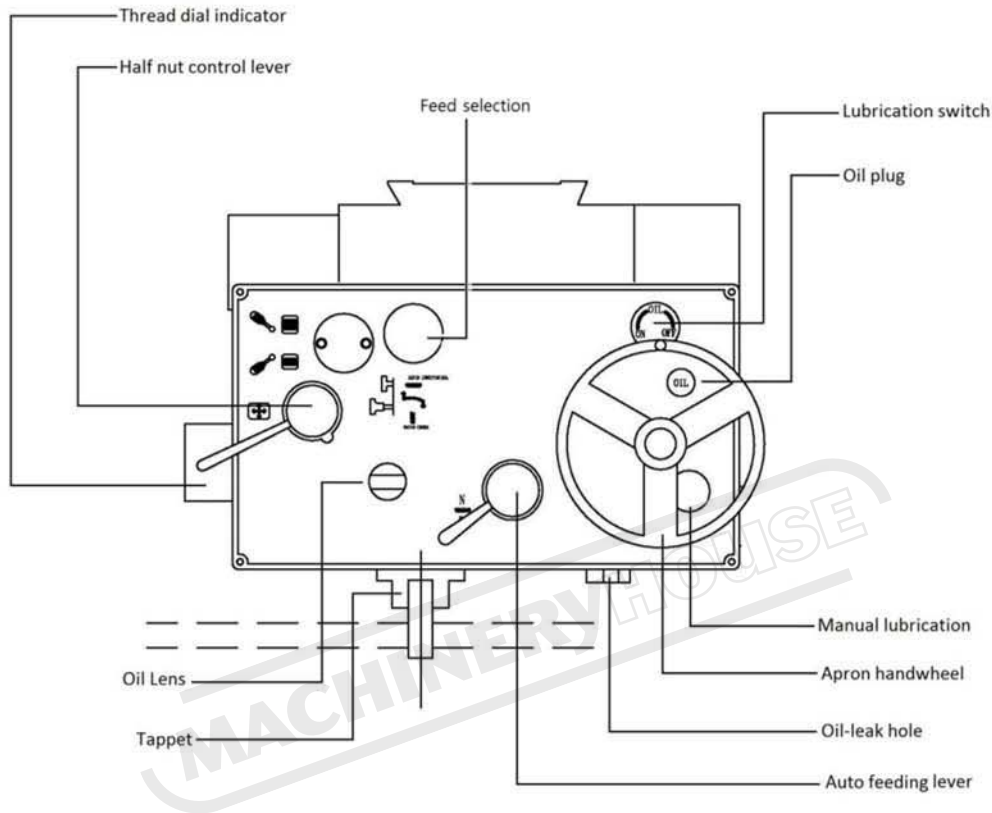

2. Apron with two auto feeding direction, cross-feed and longitudinal feed, according to the instructions of the nameplates first select operation required (pull - turn or push -turn knob) , then operate the automatically feed lever down to engage the feed. There is protection stop device under the apron of longitudinal feeding to automatically stop. To adjust the distance, loosen the stop feeding ring on the mounting screws, move the stop feeding ring to the desired position, and then fix.
3. Thread cutting drive
When doing the split nut lever down operation, split nut will combine with the lead screw and thread cutting up operation. Stop thread cutting, nursing bed inside safety bar to prevent thread cutting and automatically feed not both simultaneously to ensure safety.

4. Lubrication switch on Apron is for the control oil lubrication supply to slide. To turn off the lubrication, please turn clockwise to the end. Turn counterclockwise to start lubrication supply. Lubrication has 3 steps, from minimum to maximum only works on the process of apron moving.
5. There is a operation box at the right hand side of the apron.
6. Each button on the operation box are spindle few & back and Intermittent button for "A" .To control the spindle Intermittent run for "B", press the start button for "C" the start cutting. If want to stop the cutting, press the stop button for "C". For emergency stop ,to press the emergency button on the right hand side button of the plate to stop.

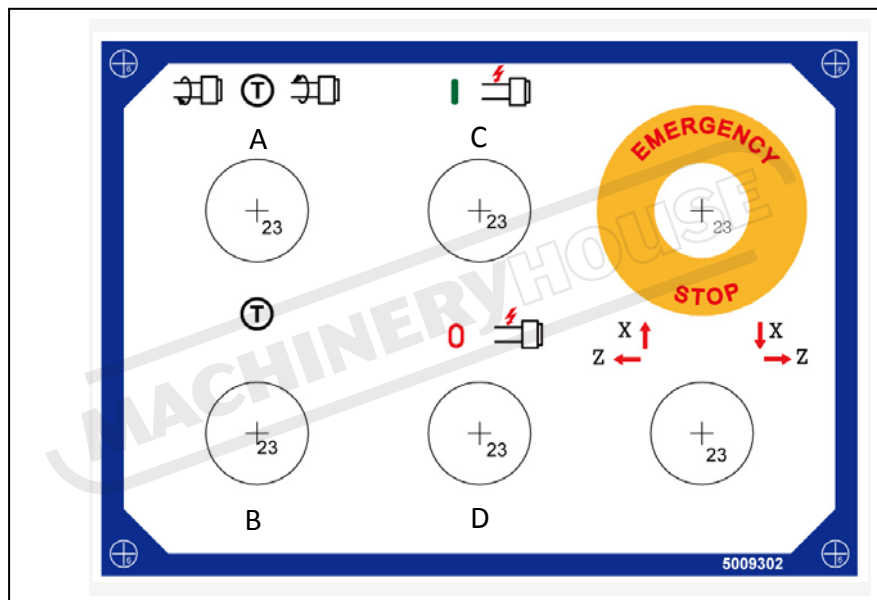

4-7 Gearbox

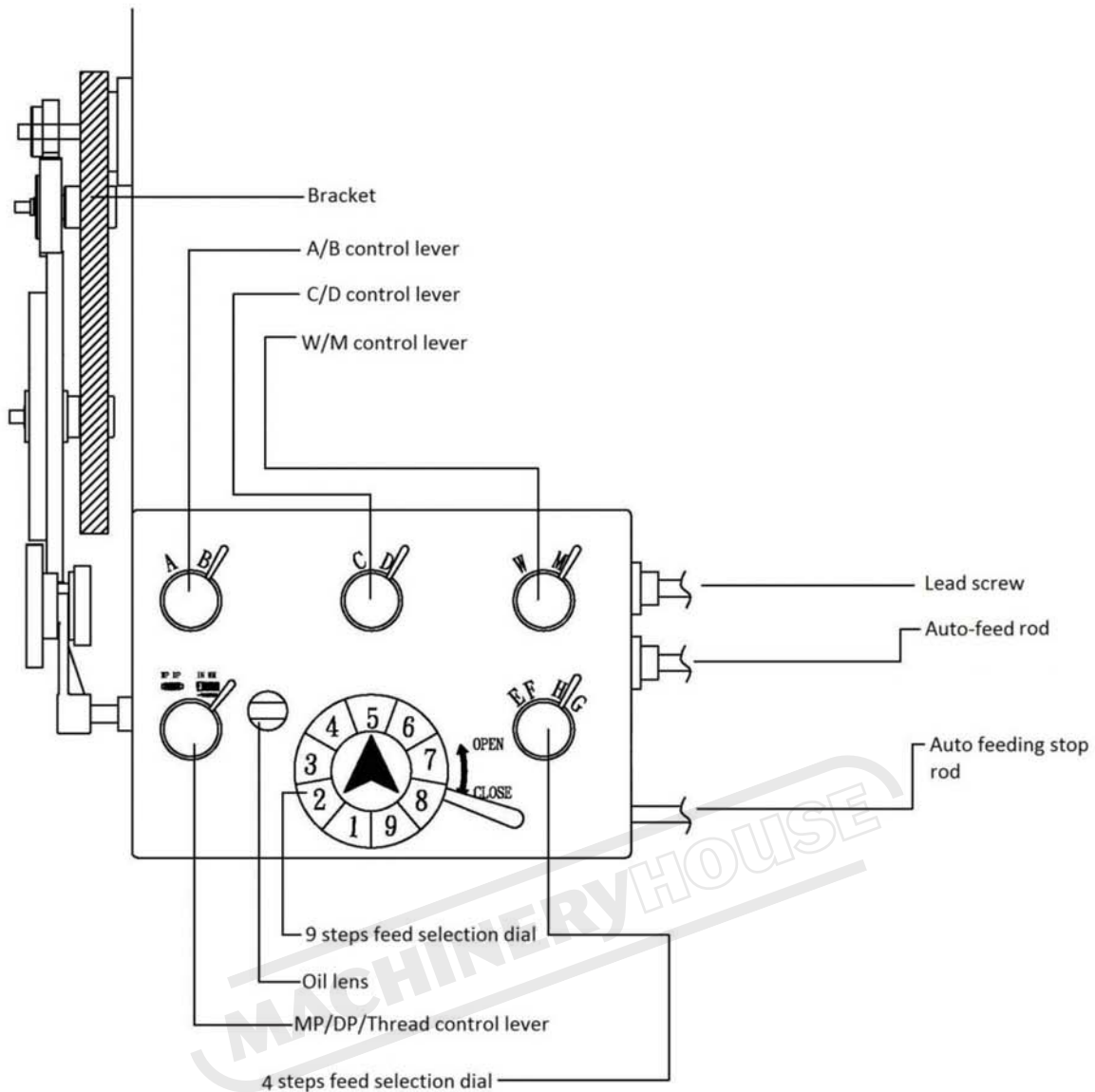

1. Transmission of Gearbox is from Headstock's forward&reverse mechanism to rear side gear change up mechanism. And then via two 2 steps and one 3 steps speed change mechanism in gear box to 9 steps speed change mechanism. Finally through feeding change mechanism to lead crew and auto-feed rod
2. Gearbox main function is thread cutting and automatic feed for cutting metric thread, but still can be cut DP and Module thread without changing any gear.
3. The thread cutting , please follow the instructions thread cutting chart of various gear lever placed in the appropriate position in order to cut the require thread pitch.
4. Automatic feed , please follow the thread cutting table indicates, depending on the desired feeding rate of the various shift lever in the proper position, then go to feed lever position, then can be automatically feeding operation.

4-8 thread indicator

Indicator means engaging with the screw thread, in accordance with the attached front table, thread pitch can be found, the exchange of these worm gear and engage the lead screw, the upper indicator with the rotation of the lead screw rotates.

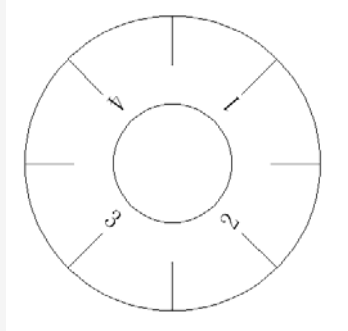

Inch with 8T the worm gear:

1. Thread cutting with $1/4$ of the pitch time, only the alignment mark with a single, repeated cutting of the original single point until complete as $2-1/4$ $2-3/4$, $2-7/8$, total one time.
2. Cutting thread $1/2$ of the pitch, the angle may be aligned either of two symmetrical scale line, such as the first target 1, the second 3 can be aligned, or aligned with the first 2, the second can be aligned with 4, 2 times.
3. Odd thread cutting teeth, you can align the mark of any four angles, such as 1,2,3,4, , total 4 times
4. Cutting thread is even thread, may be aligned at an angle of any tick of 8 times.

Metric with 10T, 11T, 12T, 13T, 14T of the Worm gear:

1. Cutting thread of 0.8,1.0,1.2 table data, use the worm gear 12T, any angle can be aligned with the mark, total 8 times.
2. Cutting thread of 0.9,2.25 table data, use the worm gear 12T, any angle can be aligned with any four angles of the mark, such as 1,2,3,4, total 4 times.
3. Cutting thread is 1.4,1.75,3.5 of table data, use the worm gear 14T can be aligned with any two symmetrical angles scale line, such as the first aligned with second time can be aligned with three, total 2 times.
4. Cutting thread is 1.25,2.5,5.0 of table data, use the worm gear 10T can be aligned either two symmetrical angles scale line, such as the first aligned with a second time can be aligned with 3, total 2 times.
5. Cutting thread is 8.0, please use the worm gear 12T can be aligned with any two symmetrical angles scale line, such as the first aligned with a second time can be aligned with 3, total 2 times.
6. Cutting thread is 1.1,2.75,5.5 of table data, use worm gear 11T can be aligned with a single mark, repeat the original single-point cutting until done only once.
7. Cutting thread of 1.3,3.25 table data, use the worm gear 13T can be aligned with single mark, repeat the original single-point cutting until done only once.

4-9 Steady rest

The function for steady rest is to fix center when clamping long and not rigidity work piece. Please tighten block-clamp to proper position, loosen screw A, rotate hand wheel to 3 quills to required position. Then after tighten screw A, please lubricate any time due to roller type tip.

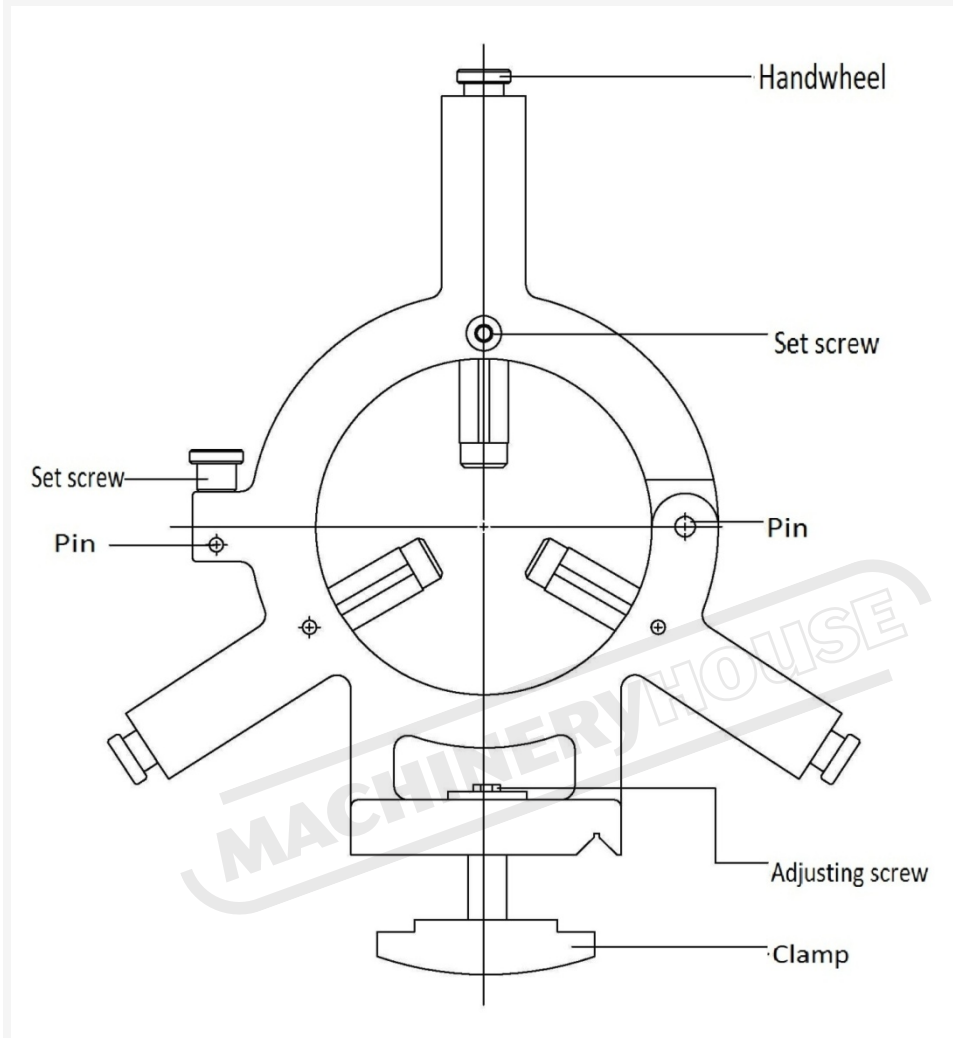

4-10 Brake system

To Please press Emergency button, the power supply will cut off immediately and motor Pulley stop running.

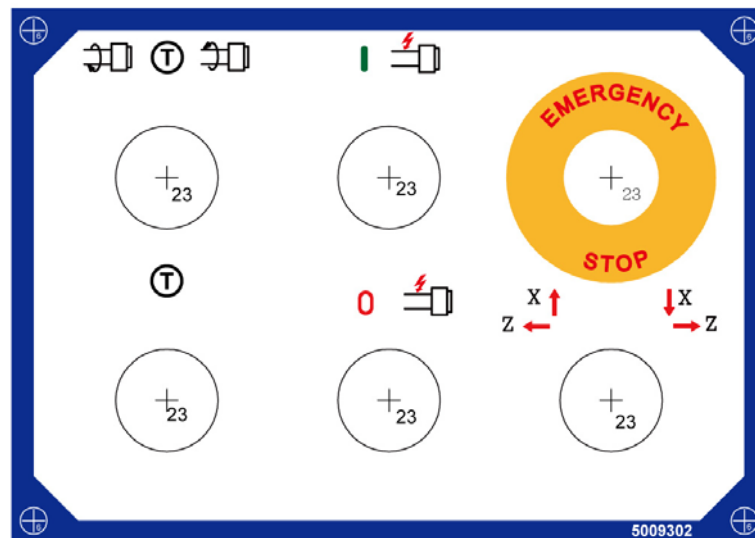

We offer pedal for brake (Distance between 3 meters), above distance between centers 3 meters we do not offer. After step pedal, the power will cut off immediately and brake lining and motor pulley will stop running.

MACHINERYHOUSE

5. LUBRICATION

5-1 Headstock Lubrication

Headstock lubrication is splash injection type. Oil grooves are equipped around the headstock to provide lubricant flowing from oil grooves to spindle, then finally reach the bottom of the headstock. To add oil, take off the oil plug on the top of the headstock cover, fill to the centerline of oil sight glass. Oil drain hole is located on the left bottom side of the headstock.

Before operating the lathe, be sure the headstock is filled with oil. If not, add Shell Tellus #32. Exchange oil after three months use for the first time. Thereafter every six months.

5-2 Gear Box & Apron Lubrication

1. Gear box is reservoir oil bath type. To ensure the long service life of gear box and bedways, exchange the oil of gear box every six months.
2. Apron is also reservoir oil bath type. Add the oil as soon as the oil is lower than the center line of the oil sight glass.

5-3 Lubrication Charts

No.	Location	Methods	Oil amount	Oil time	Exchange time	Recommend oil type
1	Headstock	Loosen the oil input hole screw on the left top side of the headstock cover	Center line		One month at the beginning, thereafter once three months	Shell Tellus #32
2	Gear Box	Open the top cover and loosen the oil input hole screw.	Center line		Every six months	Shell Tellus Omala 150
3	Apron	Loosen the oil input hole screw	Center line	Once per day		Shell Tellus T-68
4	Compound rest	Add oil with oil gun	As required	Once per day		
5	Auto Feeding rod	Add oil with oil gun	As required	Once per day		
6	Tailstock	Add oil with oil gun	As required	Once per day		
7	Leadscrew	Add oil with oil gun	As required	Once per day		
8	Bedway	Auto lubrication				

A: Oil input hole

B: Oil drain hole

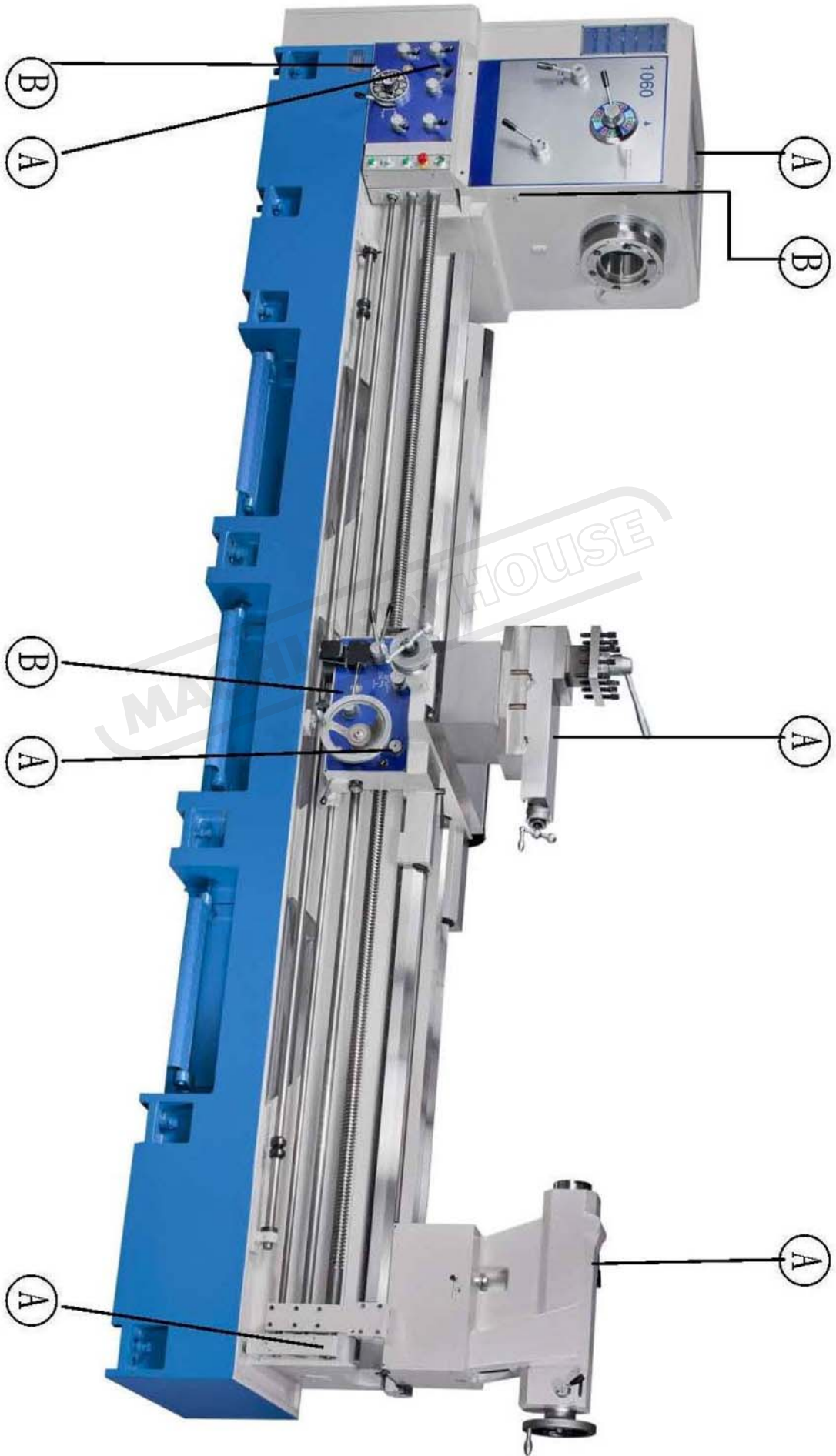

6. MAINTENANCE & ADJUSTMENT

Please refer to following items for machine problem solution and maintenance for obtaining the best function and the long service life of the lathe.

6-1 Headstock

1. To avoid the headstock cover oil leaking: Once the headstock cover is opened, use cloth to clean the connecting surface and apply some grease sealant, then can close the cover and tighten the set screw.
2. To avoid the returning oil route being blocked: There are two reasons which cause the oil leaking from headstock front cover; one is over oiled; the other is that the returning oil route is blocked. It should take off the headstock cover. Then blow air to the small hole, which is on the top of the front bearing, by air gun several times. And rotate the spindle at the same time to clean up the blocked returning oil route.
3. Spindle bearing adjustment: The front and middle bearings of the spindle is precision taper roller type. It requires to adjust the bearings to have suitable preload for maintaining the high accuracy and the best rotating functions. After long use the locking nut may be loose a little bit and result in uneven cutting surface. For adjustment, loosen the setscrew by hexagon wrench. Then tighten the locking nut to obtain the suitable preload. Do not over-tighten as over-preload will make the bearings hot, damage the rotating surface of the bearings and lower down the bearing motion functions. After adjustment, be sure to tighten the locking screw completely. Please also use dead blow hammer to hit the two sides of spindle to prevent spindle bearing damage if tilt.

6-2 Apron & Saddle

1. Apron lubrication location: on the right top side of the saddle base, the oil inlet plug marked "OIL" is the oil inlet hole.
2. Apron drain hole located on the bottom cover of the apron.
3. Oil brand and oil exchange time: Use Shell Tellus #32 and exchange the oil half a year.
4. To adjust the half nut engaged lever: After long use, the lever may be loosened and needed to be adjusted. First, take off the thread dial indicator and find the 4 gib strip adjusting screws. Second, while pressing the lever, also adjust the 4 gib strip adjusting screws until they are properly tightened. Afterwards, replace the thread dial indicator.
5. Adjustment for the longitudinal & cross auto feeding overload:
Please stop the machine before doing adjustment. The cone clutch on the right hand side of the apron is an overload device.
To Adjust, first push down feed engagement lever on the front of Apron to engage feed mechanism in apron. This will allow the clutch to be adjusted.



Tighten clockwise, the overload will increase; Tighten anticlockwise, the overload will then decrease. Disengage feed lever when done.



6-3 Gear Box

1. Lubrication location: Below the top cover of the apron, take off the top cover to find the oil plug marked "OIL", the oil inlet hole.
2. Drain hole: On the left bottom side of the 10-step feed selection dial. The screw with hexagon nut is the oil drain hole .
3. Oil brand and oil exchange time: Use Shell Tellus Omala 150 and exchange the oil half a year.

6-4 Belt Tension Adjustment

After long use, the belt will stretch and require periodic tension adjustment.

1. Take off the cover on the left back side of the lathe.
2. Loosen adjusting nut **A** and lower down the suitable height until the desired belt tension is achieved.
3. After adjustment, be sure to tighten the adjusting nut securely.



Fig 6-4

6-5 Brake Belt Adjustment

If the brake belt is worn out and cause the brake band tool loosen, it is time to adjust the nut **H** of the brake band. Remove the side rear cover, loosen the nuts on the top firstly and tighten the nuts on the bottom to the appropriate height. Then tighten the nuts on the top to complete the adjustment. After adjustment, replace the side rear cover.

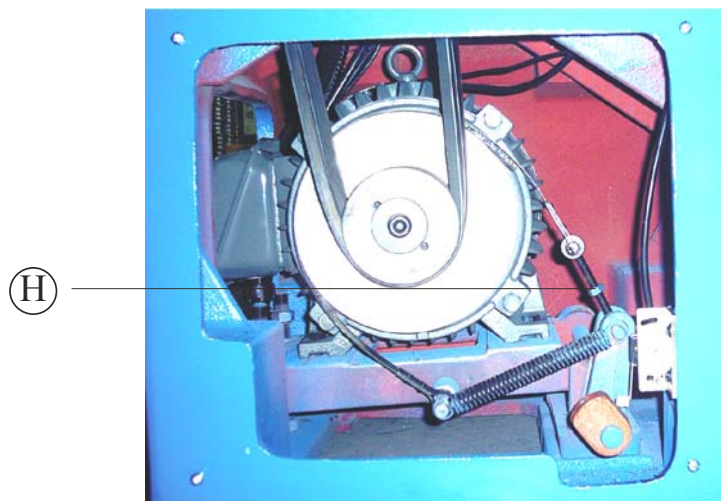

Fig 6-5

6-6 Brake & Micro Switch Adjustment

The foot brake is connected with the micro switch. It should have 0-1mm end play between the brake arm and the touching, head of the micro switch. The correct brake action should cut off the electricity first, then brake to avoid the brake belt being worn out. After stepping the foot brake, needs to re-operate the spindle operation control lever to make the spindle revolute again.

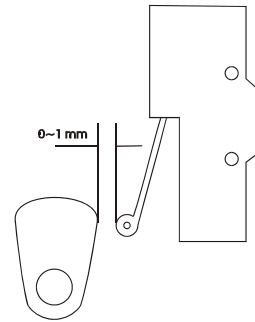
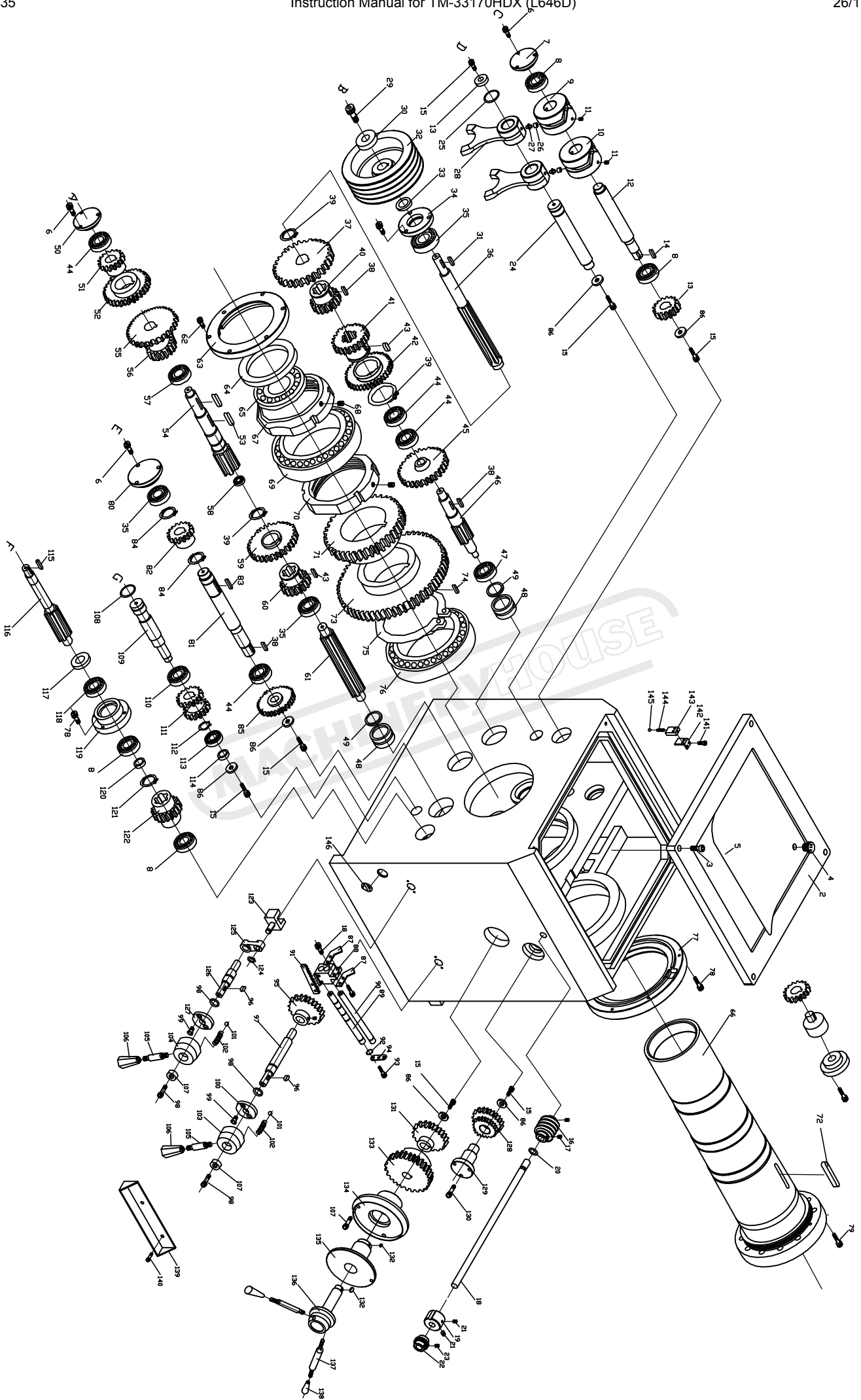

Fig. 6-6

6-7 Cutting Coolant Repair

If there is no coolant coming out after the pump switch is turned on, check the pump motor is working or not. If yes, check and see if the coolant in the tank is over the pump or not, If not, add the coolant, then turn on the switch, If there is still no coolant, the pump must be blocked. Take off the pump to clean up for repair.

MACHINERYHOUSE



HEADSTOCK ASSMBLY (spindle bore :150mm/ 6")

ITEM NO.	Part Name	Amt. Used	Model: 33" Part No.	Model: 37" Part No.	Model: 41" Part No.
1	Head stock	1	5001001-033	5001001-037	5001001-041
2	Head stock cover	1	5001002	5001002	5001002
3	Hexagon socket screw, M10xP1.25x35L	4	91111035	91111035	91111035
4	Oil plug	1	5001004	5001004	5001004
5	Blanket	1	5001005	5001005	5001005
6	Hexagon socket screw, M6xP1.0x12L	18	91110612	91110612	91110612
7	Cover	1	5001007	5001007	5001007
8	Ball bearing , 6206	4	91301021	91301021	91301021
9	Cam	1	5001009	5001009	5001009
10	Cam	1	5001011	5001011	5001011
11	Set screw, M10xP1.25x30L	8	91121030	91121030	91121030
12	Cam shaft	1	5001008	5001008	5001008
13	Worm gear 12T	1	5001013	5001013	5001013
14	Square key ,6x6x25L	1	91610625	91610625	91610625
15	Hexagon socket screw, M10xP1.25x25L	6	91111025	91111025	91111025
16	Worm bearing adjuster	1	5001016	5001016	5001016
17	Set screw, M8xP1.25x6L	2	91120806	91120806	91120806
18	Hob	1	5001018	5001018	5001018
19	Locating ring	1	5001019	5001019	5001019
20	O-RING P16	1	9151P016	9151P016	9151P016
21	Set screw, M8xP1.25x12L	2	91120812	91120812	91120812
22	Worm gear gear 20T	1	5001022	5001022	5001022
23	Set screw, M8xP1.25x6L	3	91120806	91120806	91120806
24	Radius arm axis	1	5001024	5001024	5001024
25	O-RING P29	1	9151P029	9151P029	9151P029
26	Bushing	2	5001026	5001026	5001026
27	Pin	2	5001027	5001027	5001027
28	Radius arm	2	5001028	5001028	5001028
29	Hexagon socket screw, M12x25L	1	91111225	91111225	91111225
30	Spring-washer M12	1			
31	Square key ,10x10x55L	1	91611055	91611055	91611055
32	Pulley wheel	1	5001032	5001032	5001032
33	Seal-oil, TC 34x52x11	1	91523452	91523452	91523452
34	Cover	1	5001034	5001034	5001034
35	Ball bearing , 6307	3	61306307	61306307	61306307
36	Shaft-B	1	5001036	5001036	5001036
37	Gear 59T	1	5001037	5001037	5001037
38	Square key ,10x10x30L	3	91611030	91611030	91611030
39	Snap ring, S55	3	9171S055	9171S055	9171S055
40	Gear 41T	1	5001040	5001040	5001040
41	Gear 32T	1	5001041	5001041	5001041

HEADSTOCK ASSMBLY (spindle bore :150mm/ 6")

ITEM NO.	Part Name	Amt. Used	Model: 33" Part No.	Model: 37" Part No.	Model: 41" Part No.
42	Gear 51T	1	5001042	5001042	5001042
43	Square key ,10x10x25L	2	91611025	91611025	91611025
44	Ball bearing , 6207	4	91306207	91306207	91306207
45	Gear 58T	1	5001045	5001045	5001045
46	Gear sahft 23T	1	5001046	5001046	5001046
47	Ball bearing , 6208	1	91306208	91306208	91306208
48	Plug A&B	2	5001048	5001048	5001048
49	O-RING P70	2	9151P070	9151P070	9151P070
50	Cover	1	5001050	5001050	5001050
51	Gear 43T	1	5001051	5001051	5001051
52	Gear 61T	1	5001052	5001052	5001052
53	Square key ,10x10x90L	2	91611090	91611090	91611090
54	Gear sahft 27T	1	5001054	5001054	5001054
55	Gear 70T	1	5001055	5001055	5001055
56	Gear 51T	1	5001056	5001056	5001056
57	Ball bearing , 6209	1	91306209	91306209	91306209
58	Ball bearing , NJ205	1	9131J205	9131J205	9131J205
59	Gear 27T/62T	1	5001059	5001059	5001059
60	Gear 22T	1	5001060	5001060	5001060
61	Shaft	1	5001061	5001061	5001061
62	Hexagon socket screw, M6xP1.0x25L	8	91110625	91110625	91110625
63	Cover	1	5001063	5001063	5001063
64	Seal-oil, TC 180x210x15	1	91521802	91521802	91521802
65	Ball bearing , 6836	1	91306836	91306836	91306836
66	Spindle (A2-11)	1	5001066	5001066	5001066
67	Lock-nut	1	5001067	5001067	5001067
68	Set screw, M12xP1.25x20L	6	91121220	91121220	91121220
69	Taper roller bearing , 32938	1	91332938	91332938	91332938
70	Lock-nut	1	5001070	5001070	5001070
71	Gear	1	5001071	5001071	5001071
72	Square key ,15x15x80L	1	91611580	91611580	91611580
73	Gear	1	5001074	5001074	5001074
74	Square key ,12x12x40L	1	91611240	91611240	91611240
75	Snap ring, S220	1	9171S220	9171S220	9171S220
76	Taper roller bearing , 32940	1	91332940	91332940	91332940
77	Cover	1	5001077	5001077	5001077
78	Hexagon socket screw, M6xP1.0x35L	10	91110635	91110635	91110635
79	Hexagon socket screw, M20xP2.5x55L	11	91112055	91112055	91112055
80	Cover	1	5001080	5001080	5001080
81	Shaft	1	5001081	5001081	5001081
82	Gear	1	5001082	5001082	5001082
83	Square key ,10x10x45L	1	91611045	91611045	91611045
84	Snap ring, S38	2	9171S038	9171S038	9171S038
85	Gear 42T	1	5001085	5001085	5001085
86	Lap	5	5001086	5001086	5001086

HEADSTOCK ASSMBLY (spindle bore :150mm/ 6")

ITEM NO.	Part Name	Amt. Used	Model: 33" Part No.	Model: 37" Part No.	Model: 41" Part No.
87	Dials the fingernail	2	5001087	5001087	5001087
88	Speed change slide	1	5001088	5001088	5001088
89	Localization axis	1	5001089	5001089	5001089
90	Guide rod	1	5001090	5001090	5001090
91	Change speed gear 36T	1	5001091	5001091	5001091
92	O-RING P21	3	9151P021	9151P021	9151P021
93	Hexagon socket screw, M6xP1.0x20L	3	91110620	91110620	91110620
94	Files piece	1	5001094	5001094	5001094
95	Change speed gear	1	5001095	5001095	5001095
96	Square key ,5x5x15L	2	91610501	91610501	91610501
97	Shaft	1	5001097	5001097	5001097
98	O-RING P18	1	9151P018	9151P018	9151P018
99	Screw , M6xP1.0x14L	4			
100	Detent plate	1	5001100	5001100	5001100
101	Ball steel , φ5/16"	3	91820516	91820516	91820516
102	Spring, D8xd0.8x25L	3			
103	Hub	1	5001103	5001103	5001103
104	Hub	1	5001104	5001104	5001104
105	Lever	2	3001114	3001114	3001114
106	Knob	2	3001115	3001115	3001115
107	Washer	2			
108	O-RING P29	1	9151P029	9151P029	9151P029
109	Shaft -G	1	5001109	5001109	5001109
110	Ball bearing , 6006	1	91301013	91301013	91301013
111	Gear	1	5001111	5001111	5001111
112	Snap ring, R48	1	9171R048	9171R048	9171R048
113	Ball bearing , 6005	1	91306005	91306005	91306005
114	Retainer G	1	5001114	5001114	5001114
115	key ,6x6x25L	1	91620625	91620625	91620625
116	Output shaft	1	5001116	5001116	5001116
117	Seal-oil, TC 30x50x8	1	91523050	91523050	91523050
118	Ball bearing , 6906	1	91306906	91306906	91306906
119	Lever	1	5001119	5001119	5001119
120	Retainer F	1	4001010	4001010	4001010
121	Snap ring, S38	1	9171S038	9171S038	9171S038
122	Gear	1	5001122	5001122	5001122
123	Dials the block	2	5001123	5001123	5001123
124	Snap ring, S10	1	9171S010	9171S010	9171S010
125	Rocking shaft	1	3501117	3501117	3501117
126	Work driving arm F	1	5001126	5001126	5001126
127	Detent plate F	1	5001127	5001127	5001127
128	Gear 60T/80T	1	5001128	5001128	5001128
129	Left fixed stand	1	5001129	5001129	5001129
130	Hexagon socket screw, M10xP1.5x15L	3	91111015	91111015	91111015
131	First change speed gear A 40T	1	5001131	5001131	5001131
132	Square key ,6x6x12L	2	91610601	91610601	91610601
133	First change speed gear B 60T	1	5001133	5001133	5001133

HEADSTOCK ASSMBLY (spindle bore :150mm/ 6")

ITEM NO.	Part Name	Amt. Used	Model: 33" Part No.	Model: 37" Part No.	Model: 41" Part No.
134	Speed change fixed stand	1	5001134	5001134	5001134
135	Speed change kneading board	1	5001135	5001135	5001135
136	Speed change hand	1	5001136	5001136	5001136
137	Lever	2	3003017	3003017	3003017
138	Knob	2	3003018	3003018	3003018
139	Sets at the frame	1	5001139	5001139	5001139
140	Hexagon socket screw, M5xP0.8x15L	2	91110515	91110515	91110515
141	Hexagon socket screw, M5xP0.8x25L	2	91110525	91110525	91110525
142	Base support	1	5001141	5001141	5001141
143	Locates the base	1	5001140	5001140	5001140
144	Ball steel	1			
145	Spring	1			
146	Lenz-oil , ϕ 29	1	92552001	92552001	92552001

MACHINERYHOUSE

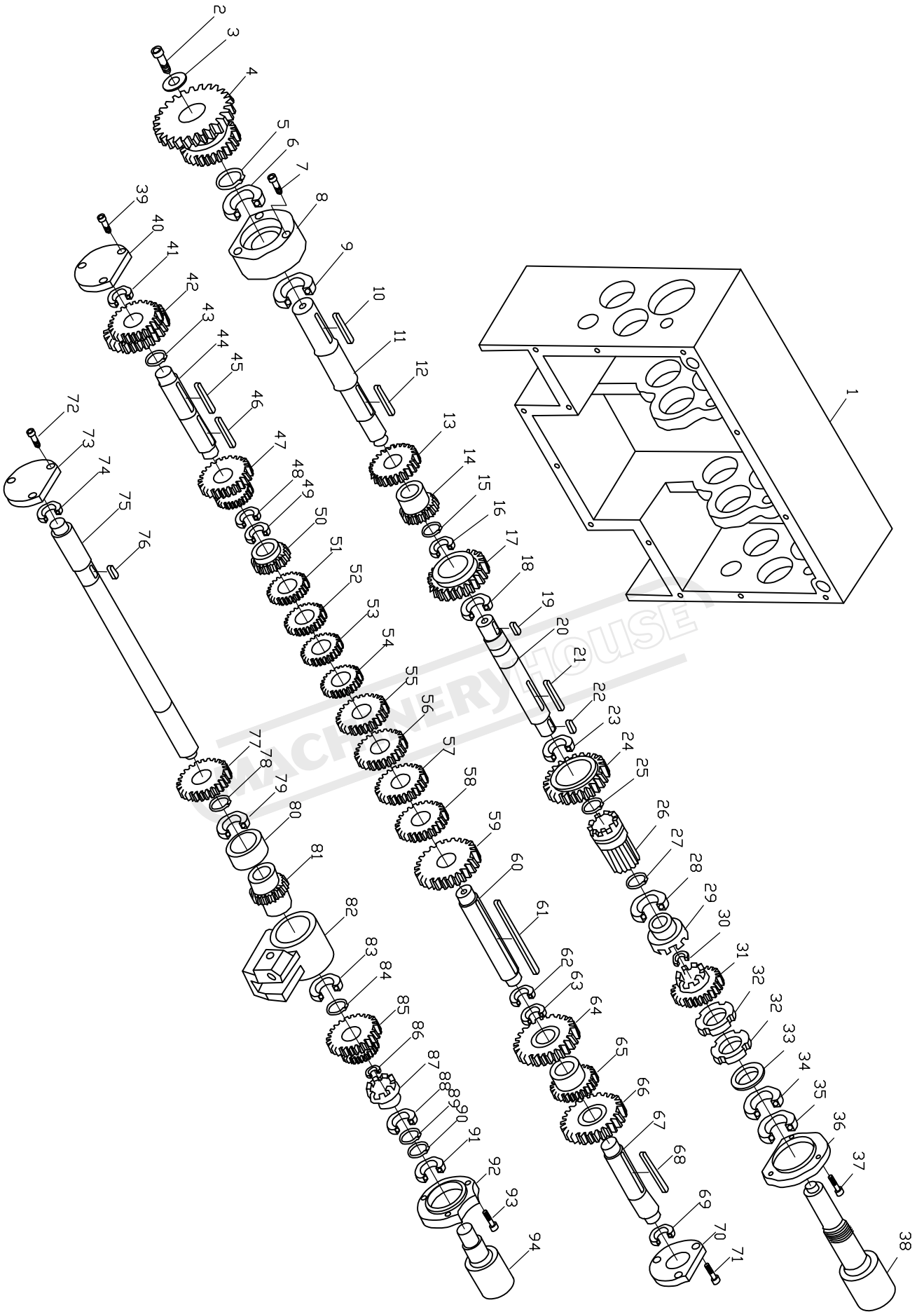

9-2-1 Gear Box

GEAR BOX ASSEMBLY

ITEM NO.	Part Name	Amt. Used	Model: 33" Part No.	Model: 37" Part No.	Model: 41" Part No.
1	GEAR BOX	1	5002001	5002001	5002001
2	BOLT M8X25L	1	91110825	91110825	91110825
3	WASHER	1			
4	GEAR	1	5002004	5002004	5002004
5	SNAP RING	1			
6	BEARING 6006	1			
7	BOLT M6X50L	3	91110650	91110650	91110650
8	COVER	1	5002008	5002008	5002008
9	BEARING 6206	1			
10	KEY 6X6X55L	1			
11	SHAFT	1	5002011	5002011	5002011
12	KEY 6X6X50L	1			
13	GEAR	1	5002013	5002013	5002013
14	GEAR	1	5002014	5002014	5002014
15	SNAP RING	1			
16	BEARING 6203	1	91301016	91301016	91301016
17	GEAR	1	5002017	5002017	5002017
18	BEARING 6205	1			
19	KEY 6X6X20L	1			
20	SHAFT	1	5002020	5002020	5002020
21	KEY 6X6X50L	1			
22	KEY 6X6X20L	1			
23	BEARING 6005	1	91301010	91301010	91301010
24	GEAR	1	5002024	5002024	5002024
25	SNAP RING	1			
26	GEAR	1	5002026	5002026	5002026
27	SNAP RING	1			
28	BEARING 6006	1			
29	CLUTEH	1	5002029	5002029	5002029
30	BEARING 6002	1			
31	GEAR	1	5002031	5002031	5002031
32	NUT	2			
33	WASHER	1			
34	BEARING 30206	1			
35	BEARING 30206	1			
36	COVER	1	5002036	5002036	5002036
37	BOLT M6X25L	1	91110625	91110625	91110625
38	SHAFT	1	5002038	5002038	5002038
39	BOLT M6X16L	3	91110616	91110616	91110616
40	COVER	1	5002040	5002040	5002040
41	BEARING 6204	1	91301018	91301018	91301018
42	GEAR	1	5002042	5002042	5002042
43	SNAP RING	1			
44	SHAFT	1	5002044	5002044	5002044
45	KEY 6X6X55L	1			
46	KEY 6X6X55L	1			
47	GEAR	1	5002047	5002047	5002047
48	BEARING 6204	1	91301018	91301018	91301018
49	BEARING 6204	3	91301018	91301018	91301018

GEAR BOX ASSEMBLY

ITEM NO.	Part Name	Amt. Used	Model: 33" Part No.	Model: 37" Part No.	Model: 41" Part No.
50	GEAR	1	5002050	5002050	5002050
51	GEAR	1	5002051	5002051	5002051
52	GEAR	1	5002052	5002052	5002052
53	GEAR	1	5002053	5002053	5002053
54	GEAR	1	5002054	5002054	5002054
55	GEAR	1	5002055	5002055	5002055
56	GEAR	1	5002056	5002056	5002056
57	GEAR	1	5002057	5002057	5002057
58	GEAR	1	5002058	5002058	5002058
59	GEAR	1	5002059	5002059	5002059
60	SHAFT	1	5002060	5002060	5002060
61	KEY 6X6X130L	1			
62	BEARING 6204	1	91301018	91301018	91301018
63	BEARING 6204	1	91301018	91301018	91301018
64	GEAR	1	5002064	5002064	5002064
65	GEAR	1	5002065	5002065	5002065
66	GEAR	1	5002066	5002066	5002066
67	KEY 6X6X70L	1			
68	SHAFT	1	5002068	5002068	5002068
69	BEARING 6204	1	91301018	91301018	91301018
70	COVER	1	5002070	5002070	5002070
71	BOLT M6X16L	3	91110616	91110616	91110616
72	BOLT M6X16L	3	91110616	91110616	91110616
73	COVER	1	5002073	5002073	5002073
74	BEARING 6204	1	91301018	91301018	91301018
75	SHAFT	1	5002075	5002075	5002075
76	KEY 6X6X20L	1			
77	GEAR	1	5002077	5002077	5002077
78	SNAP RING	1			
79	BEARING 6205	1			
80	WASHER	1	5002080	5002080	5002080
81	GEAR	1	5002081	5002081	5002081
82	GEAR BOD	1	5002082	5002082	5002082
83	BEARING 6205	1			
84	SNAP RING	1			
85	GEAR	1	5002085	5002085	5002085
86	BEARING 6002	1			
87	CLUTEH	1	5002087	5002087	5002087
88	BEARING 6006	1			
89	SNAP RING	1			
90	SNAP RING	1			
91	BEARING 6005	1	91301010	91301010	91301010
92	COVER	1	5002092	5002092	5002092
93	BOLT M6X16L	3	91110616	91110616	91110616
94	SHAFT	1	5002094	5002094	5002094

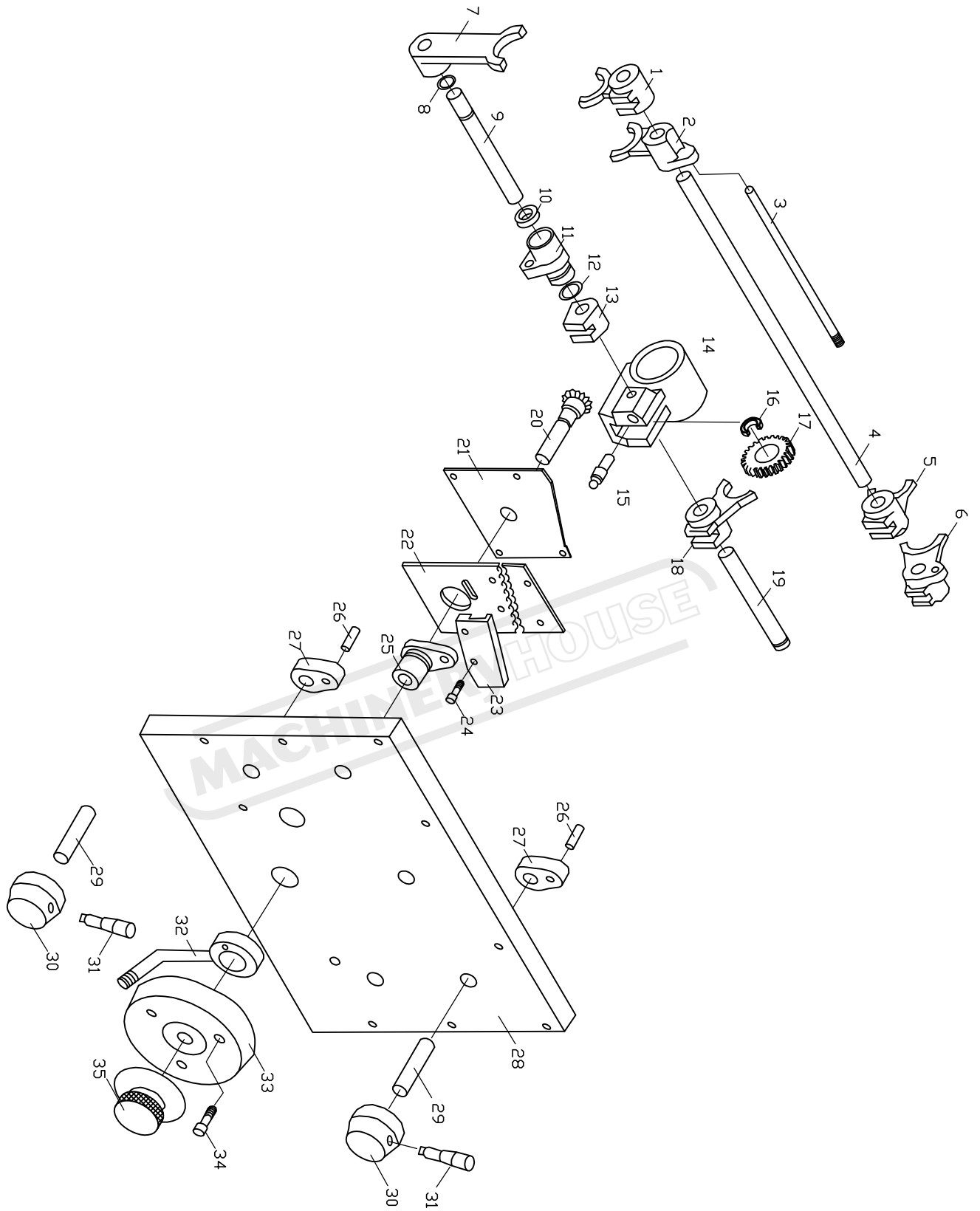

9-2-2 Gear Cover

GEAR BOX ASSEMBLY

ITEM NO.	Part Name	Amt. Used	Model: 33" Part No.	Model: 37" Part No.	Model: 41" Part No.
1	Claw-shifter	1	5002101	5002101	5002101
2	Claw-shifter	1	5002102	5002102	5002102
3	SHAFT	1	5002103	5002103	5002103
4	SHAFT	1	5002104	5002104	5002104
5	Claw-shifter	1	5002105	5002105	5002105
6	Claw-shifter	1	5002106	5002106	5002106
7	Claw-shifter	1	5002107	5002107	5002107
8	SNAP RING	1			
9	SHAFT	1	5002109	5002109	5002109
10	O-RING TC16267	1			
11	COVER	1	5002111	5002111	5002111
12	O-RING	1			
13	Claw-shifter	1	5002113	5002113	5002113
14	GEAR BOD	1	5002114	5002114	5002114
15	SHAFT	1	5002115	5002115	5002115
16	BEARING 6200	1			
17	GEAR	1	5002117	5002117	5002117
18	Claw-shifter	1	5002118	5002118	5002118
19	SHAFT	1	5002119	5002119	5002119
20	GEAR SHAFT	1	5002120	5002120	5002120
21	SLIDE PLATE	1	5002121	5002121	5002121
22	SETTING PLATE	1	5002122	5002122	5002122
23	COVER	1	5002123	5002123	5002123
24	BOLT	1			
25	Shifter	1	5002125	5002125	5002125
26	SAFT	5	5002126	5002126	5002126
27	Shifter	5	5002127	5002127	5002127
28	GEAR COVER	1	5002128	5002128	5002128
29	Shaft-shifter	5	5002129	5002129	5002129
30	HUB	5	5002130	5002130	5002130
31	Handle	5	5002131	5002131	5002131
32	Handle	1	5002132	5002132	5002132
33	Seat-gear shifting	1	5002133	5002133	5002133
34	BOLT M8X35L	3	91110835	91110835	91110835
35	CHANGE SPEED DISK	1	5002135	5002135	5002135

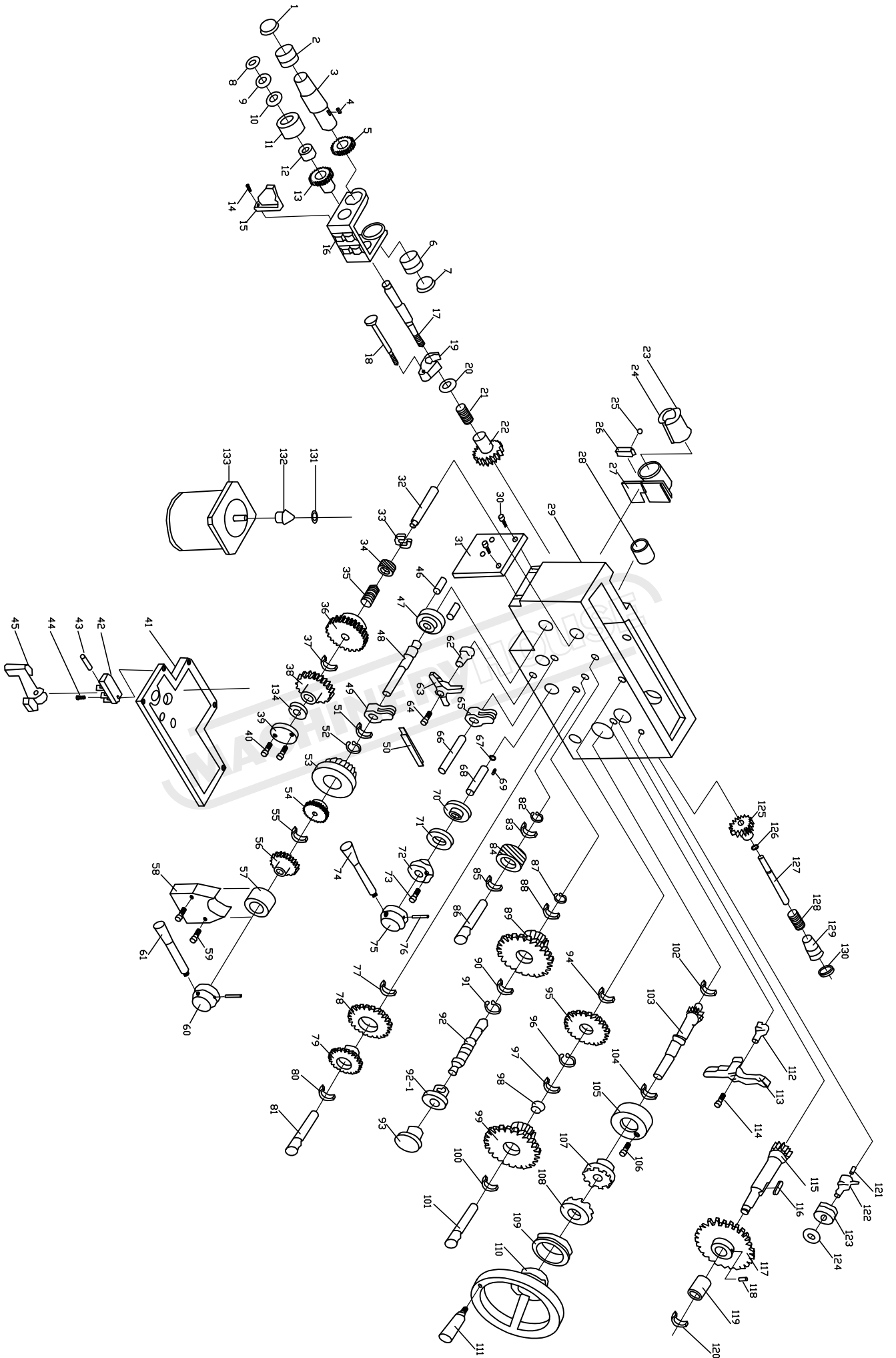

APRON ASSEMBLY

ITEM NO.	Part Name	Amt. Used	Model: 33" Part No.	Model: 37" Part No.	Model: 41" Part No.
1	OIL SEAL 40528	1			
2	BUSHING	1	5003002	5003002	5003002
3	SHAFT	1	5003003	5003003	5003003
4	KEY 6X6X20L	1			
5	GEAR	1	5003005	5003005	5003005
6	BUSHING	1	5003006	5003006	5003006
7	OIL SEAL 40528	1			
8	NUT AN03	1			
9	BEARING 51103	1			
10	BEARING 51103	1			
11	Worm gear	1	5003011	5003011	5003011
12	BUSHING	1	5003012	5003012	5003012
13	GEAR	1	5003013	5003013	5003013
14	SCREW M6X16L	2	91110616	91110616	91110616
15	RACK	1	5003015	5003015	5003015
16	Seat-worm	1	5003016	5003016	5003016
17	Shaft-worm	1	5003017	5003017	5003017
18	SHAFT	1	5003018	5003018	5003018
19	BRACKET	1	5003019	5003019	5003019
20	BEARING 51103	1			
21	SPRING	1	5003021	5003021	5003021
22	GEAR	1	5003022	5003022	5003022
23	Nut-half	1	5003023	5003023	5003023
24	Nut-half	1	5003024	5003024	5003024
25	SCREW M6X20L	2	91110620	91110620	91110620
26	REUULATOR	1	5003026	5003026	5003026
27	BRACKET	1	5003027	5003027	5003027
28	SLEEVE	1	5003028	5003028	5003028
29	APRON BOX	1	5003029	5003029	5003029
30	SCREW M6X16L	2	91110616	91110616	91110616
31	COVER	1	5003031	5003031	5003031
32	SHAFT	1	5003032	5003032	5003032
33	BEARING 51103	1			
34	GEAR	1	5003034	5003034	5003034
35	SPRING	1	5003035	5003035	5003035
36	GEAR	1	5003036	5003036	5003036
37	BEARING 6003	1			
38	GEAR	1	5003038	5003038	5003038
39	COVER	1	5003039	5003039	5003039
40	SCREW M6X16L	2	91110616	91110616	91110616
41	COVER	1	5003041	5003041	5003041
42	Seat-tappet	1	5003042	5003042	5003042
43	Shaft-tappet	1	5003043	5003043	5003043
44	SCREW M6X16L	2	91110616	91110616	91110616
45	Tappet	1	5003045	5003045	5003045
46	PIN	1			
47	SHAFT	1	5003047	5003047	5003047
48	SHAFT	1	5003048	5003048	5003048

APRON ASSEMBLY

ITEM NO.	Part Name	Amt. Used	Model: 33" Part No.	Model: 37" Part No.	Model: 41" Part No.
49	BRACKET	1	5003049	5003049	5003049
50	SHAFT	1	5003050	5003050	5003050
51	BEARING 6003	1			
52	SNAP RING S40	1	9171S040	9171S040	9171S040
53	GEAR	1	5003053	5003053	5003053
54	GEAR	1	5003054	5003054	5003054
55	BEARING 6003	1			
56	GEAR	1	5003056	5003056	5003056
57	COVER	1	5003057	5003057	5003057
58	COVER	1	5003058	5003058	5003058
59	SCREW M6X35L	2	91110635	91110635	91110635
60	HUB	1	5003060	5003060	5003060
61	HANDLE	1			
62	SHAFT	1	5003062	5003062	5003062
63	BRACKET	1	5003063	5003063	5003063
64	SCREW M12X35L	1	91111235	91111235	91111235
65	BRACKET	1	5003065	5003065	5003065
66	SHAFT	1	5003066	5003066	5003066
67	SNAP RING S16	1	9171S016	9171S016	9171S016
68	SHAFT	1	5003068	5003068	5003068
69	KEY 5X5X10L	1			
70	LEVER	1	5003070	5003070	5003070
71	LEVER	1	5003071	5003071	5003071
72	COVER	1	5003072	5003072	5003072
73	SCREW M6X16L	3	91110616	91110616	91110616
74	HANDLE	1	5003074	5003074	5003074
75	HUB	1	5003075	5003075	5003075
76	PIN	1	5003076	5003076	5003076
77	BEARING 6203	1			
78	GEAR	1	5003078	5003078	5003078
79	GEAR	1	5003079	5003079	5003079
80	BEARING 6203	1			
81	SHAFT	1	5003081	5003081	5003081
82	SNAP RING S17	1	9171S017	9171S017	9171S017
83	BEARING 6003	1			
84	GEAR	1	5003084	5003084	5003084
85	BEARING 6203	1			
86	SHAFT	1	5003086	5003086	5003086
87	SNAP RING	1			
88	BEARING 6003	1			
89	GEAR	1	5003089	5003089	5003089
90	BEARING 6003	1			
91	SNAP RING S20	1	9171S020	9171S020	9171S020
92	SHAFT	1	5003092	5003092	5003092
93	HANDLE	1	5003093	5003093	5003093
94	BEARING 6003	1			
95	GEAR	1	5003095	5003095	5003095
96	SNAP RING R35	1	9171R035	9171R035	9171R035

APRON ASSEMBLY

ITEM NO.	Part Name	Amt. Used	Model: 33" Part No.	Model: 37" Part No.	Model: 41" Part No.
97	BEARING 6003	1			
98	WASHER	1	5003098	5003098	5003098
99	GEAR	1	5003099	5003099	5003099
100	BEARING 6003	1			
101	SHAFT	1	5003101	5003101	5003101
102	BEARING 6203	1			
103	GEAR SHAFT	1	5003103	5003103	5003103
104	BEARING 6005	1			
105	COVER	1	50031105	50031105	50031105
106	SCREW M6X16L	3	91110616	91110616	91110616
107	Coupling	1	5003107	5003107	5003107
108	Coupling	1	5003108	5003108	5003108
109	Dial-rack	1	5003109	5003109	5003109
110	HAND WHEEL	1	5003110	5003110	5003110
111	HANDLE	1	5003111	5003111	5003111
112	SHAFT	1	5003112	5003112	5003112
113	BEACKET	1	5003113	5003113	5003113
114	SCREW M12X30L	1	91111230	91111230	91111230
115	GEAR SHAFT	1	5003115	5003115	5003115
116	KEY 8X8X30L	1			
117	GEAR	1	5003117	5003117	5003117
118	SCREW M16X12L	1	91111612	91111612	91111612
119	BUSHING	1	5003119	5003119	5003119
120	BEARING 6203	1			
121	PIN	1			
122	SHAFT	1	5003122	5003122	5003122
123	HANDLE	1	5003123	5003123	5003123
124	COVER	1	5003124	5003124	5003124
125	GEAR	1	5003125	5003125	5003125
126	SNAP GING S12	1	9171S012	9171S012	9171S012
127	SHAFT	1	5003127	5003127	5003127
128	SPRING	1	5003128	5003128	5003128
129	SHAFT	1	5003129	5003129	5003129
130	OIL SEAL 13246	1			
131	CONVEX TOP PLATE	1	5003131	5003131	5003131
132	GEAR	1	5003132	5003132	5003132
133	MOTOR	1			

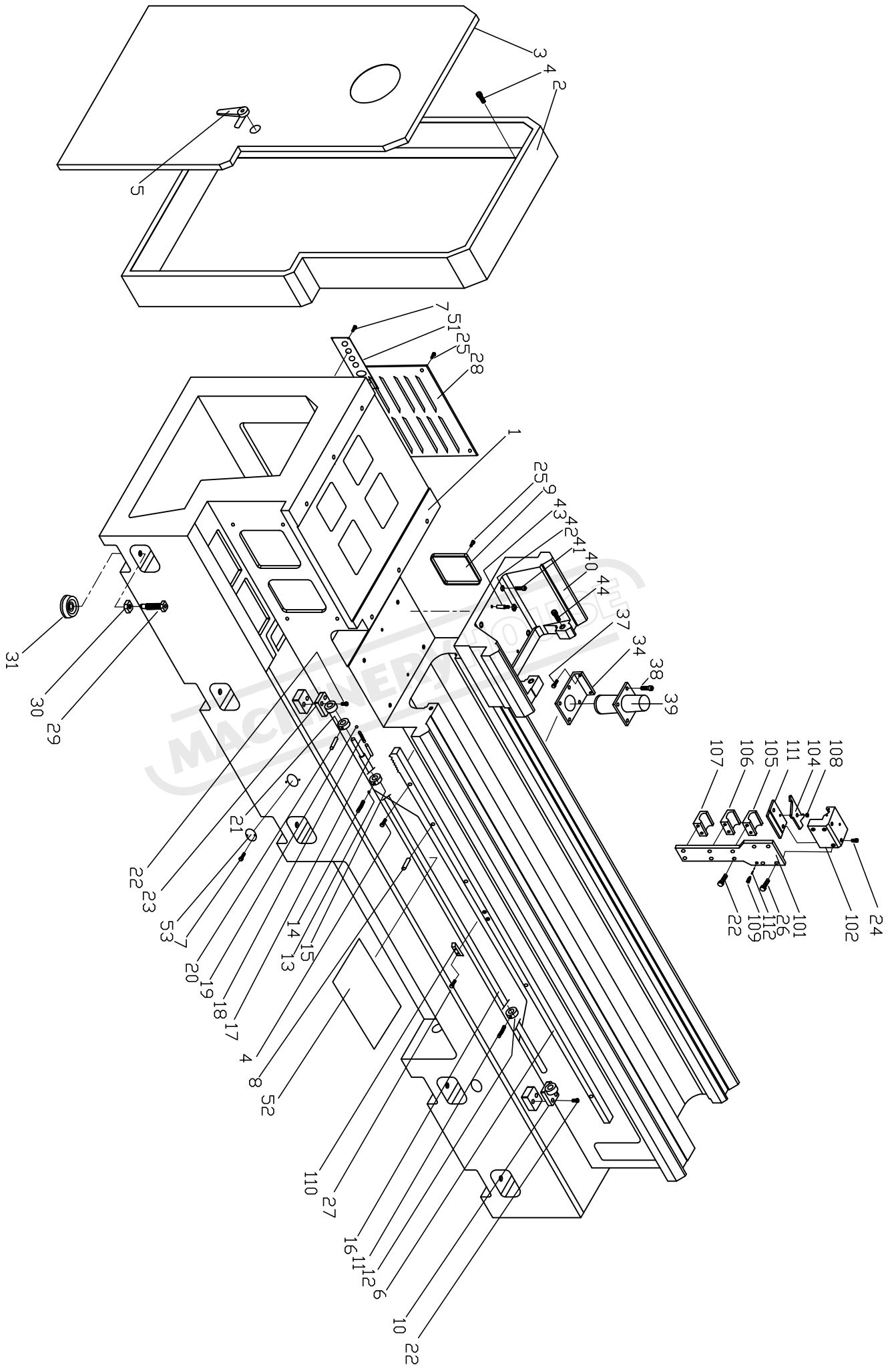

BED AND BASE ASSEMBLY

ITEM NO.	Part Name	Amt. Used	Model: 33" Part No.	Model: 37" Part No.	Model: 41" Part No.
1	Bed & Base	1			
	(8 feet)		5004001-008	5004001-008	5004001-008
	(10 feet)		5004001-010	5004001-010	5004001-010
	(15 feet)		5004001-015	5004001-015	5004001-015
2	Cover	1	5004002-033	5004002-037	5004002-041
3	Cover-end	1	5004003-033	5004003-037	5004003-041
4	Hexagon socket screw, M6xP1.0x25L	8	91110625	91110625	91110625
5	Handle	1			
6	Rack (8 feet)	1	5004006-008	5004006-008	5004006-008
	(10 feet)	1	5004006-010	5004006-010	5004006-010
	(15 feet)	1	5004006-015	5004006-015	5004006-015
7	Hexagon socket screw, M5xP0.8x15L	10	91110515	91110515	91110515
8	Pin-taper,6x35 (8 feet)	2			
	(10 feet)	5			
	(15 feet)	5			
9	Cover-coolant motor seat (with socket hole)	1	3004035	3004035	3004035
	motor seat (without socket hole)	1	3004035-001	3004035-001	3004035-001
10	Supporter-shaft	1	3004010	3004010	3004010
11	Set screw, M6xP1.0x10L	2	91120610	91120610	91120610
12	Collar	1	3004012	3004012	3004012
13	Shoe-brass	4	3004013	3004013	3004013
14	Set screw, M6xP1.0x6L	1	91120606	91120606	91120606
15	Cam-auto feed stopping	4	3004015	3004015	3004015
16	Shaft-auto stopping (8 feet)	1	5004016-008	5004016-008	5004016-008
	(10 feet)	1	5004016-010	5004016-010	5004016-010
	(15 feet)	1	5004016-015	5004016-015	5004016-015
17	Set screw, M8xP1.25x8L	1	91120808	91120808	91120808
18	Spring , 1x6x10L	1	4004018	4004018	4004018
19	Ball steel , 1/4"	1	91820104	91820104	91820104
20	Lever-turning shaft	4	3004020	3004020	3004020
21	Collar	1	3004021	3004021	3004021
22	Hexagon socket screw, M8xP1.25x16L	14	91110816	91110816	91110816
23	Supporter-shaft	1	3004023	3004023	3004023
24	Hexagon socket screw, M10xP1.25x80L	2	91111080	91111080	91111080
25	Head, M6xP1.0x20L	4			
26	Hexagon socket screw, M8xP1.25x20L	4	91110820	91110820	91110820
28	Cover-motor seat	2	3504028	3504028	3504028

BED AND BASE ASSEMBLY

ITEM NO.	Part Name	Amt. Used	Model: 33" Part No.	Model: 37" Part No.	Model: 41" Part No.
29	Bolt-set machine	5	3004029	3004029	3004029
30	Nut-lock	5	3004030	3004030	3004030
31	Block-leveling	5	3004031	3004031	3004031
34	Seat-coolant pump	1	5004034	5004034	5004034
37	Bolt-hexa. head , M8x38L	2			
40	gap	1	5004040	5004040	5004040
41	Hexagon socket screw, M12xP1.0x25L	4	91111225	91111225	91111225
42	Nut-lock , M6	2			
43	Pin ϕ 7x40L	2			
44	Hexagon socket screw, M10xP1.25x35L	2	91111035	91111035	91111035
51	Connect board	1	5004051	5004051	5004051
52	Tank cover	1	5004052	5004052	5004052
53	Cover	4	5004053	5004053	5004053
101	Bracket	1	5004101	5004101	5004101
102	Slide plate	1	5004102	5004102	5004102
104	bracket	1	5004104	5004104	5004104
105	supporter-upside	1	5004105	5004105	5004105
106	supporter-middle	1	5004106	5004106	5004106
107	supporter-	1	5004107	5004107	5004107
108	screw	1	5004108	5004108	5004108
109	bolt-set	1	5004109	5004109	5004109
110	block	1	5004110	5004110	5004110
111	steady block	1	5004111	5004111	5004111
112	spring	1	5004112	5004112	5004112

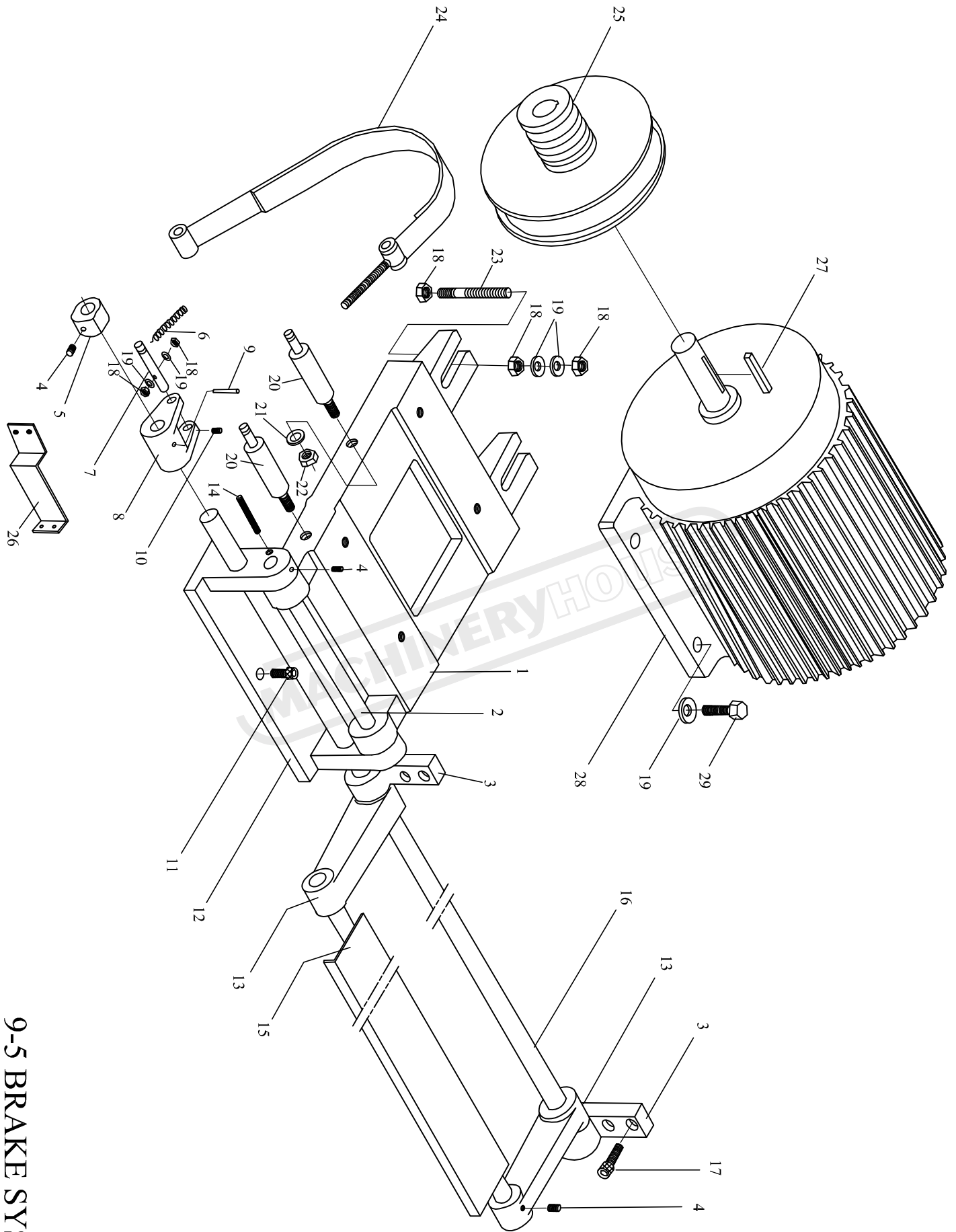

9-5 BRAKE SYSTEM

BRAKE SYSTEM

ITEM NO.	Part Name	Amt. Used	Model: 33" Part No.	Model: 37" Part No.	Model: 41" Part No.
1	Seat-motor	1	5005001	5005001	5005001
2	Shaft-motor seat	1	4005002	4005002	4005002
3	Block	2	4005003	4005003	4005003
4	Set screw, M6xP1.0x12L	1	91120612	91120612	91120612
5	Cam	1	3005005-020	3005005-022	3005005-026
6	Spring	1	4005006	4005006	4005006
7	Shaft-brake belt	1	3005007	3005007	3005007
8	Arm-brake	1	5005008	5005008	5005008
9	Pin-taper , 4x38L	1			
10	Set screw, M6xP1.0x10L	1	91120610	91120610	91120610
11	Hexagon socket screw, M10xP1.5x30L	3	91111030	91111030	91111030
12	Bracket-motor seat	1	5005012	5005012	5005012
13	Bracket-pedal	2	3005013	3005013	3005013
14		1			
15	Pedal-brake (8 feet)	1	3005015-008	3005015-008	3005015-008
	(10 feet)	1	3005015-010	3005015-010	3005015-010
	(15 feet)	1	3005015-015	3005015-015	3005015-015
16	Shaft-pedal bracket				
	(8 feet)	1	5005016-008	5005016-008	5005016-008
	(10 feet)	1	5006016-010	5006016-010	5006016-010
	(15 feet)	1	5006016-015	5006016-015	5006016-015
17	Hexagon socket screw, M8xP1.25x25L	4	91110825	91110825	91110825
18	Nut , M16	8			
19	Washer , M16	6			
20	Bolt-adjusting	2	5005020	5005020	5005020
21	Washer , M12	1			
22	Nut , M12	1			
23	Bolt-adjusting	1	4005023	4005023	4005023
24	Belt-brake	1	5005024	5005024	5005024
25	Belt pulley	1			
	(20HP/60HZ)	1	5005025	5005025	5005025
	(25HP/30HP/50HZ)	1	5005025-001	5005025-001	5005025-001
	(20HP/50HZ)	1	5005025-002	5005025-002	5005025-002
	(25HP/30hp/60HZ)	1	5005025-003	5005025-003	5005025-003
26	Bracket	1	5005026	5005026	5005026
27	Key ,12x12x55L	1			
	Key ,14x14x55L				
28	Motor	1			
29	Bolt-hexa. Head, M10x30L	4	91111030	91111030	91111030

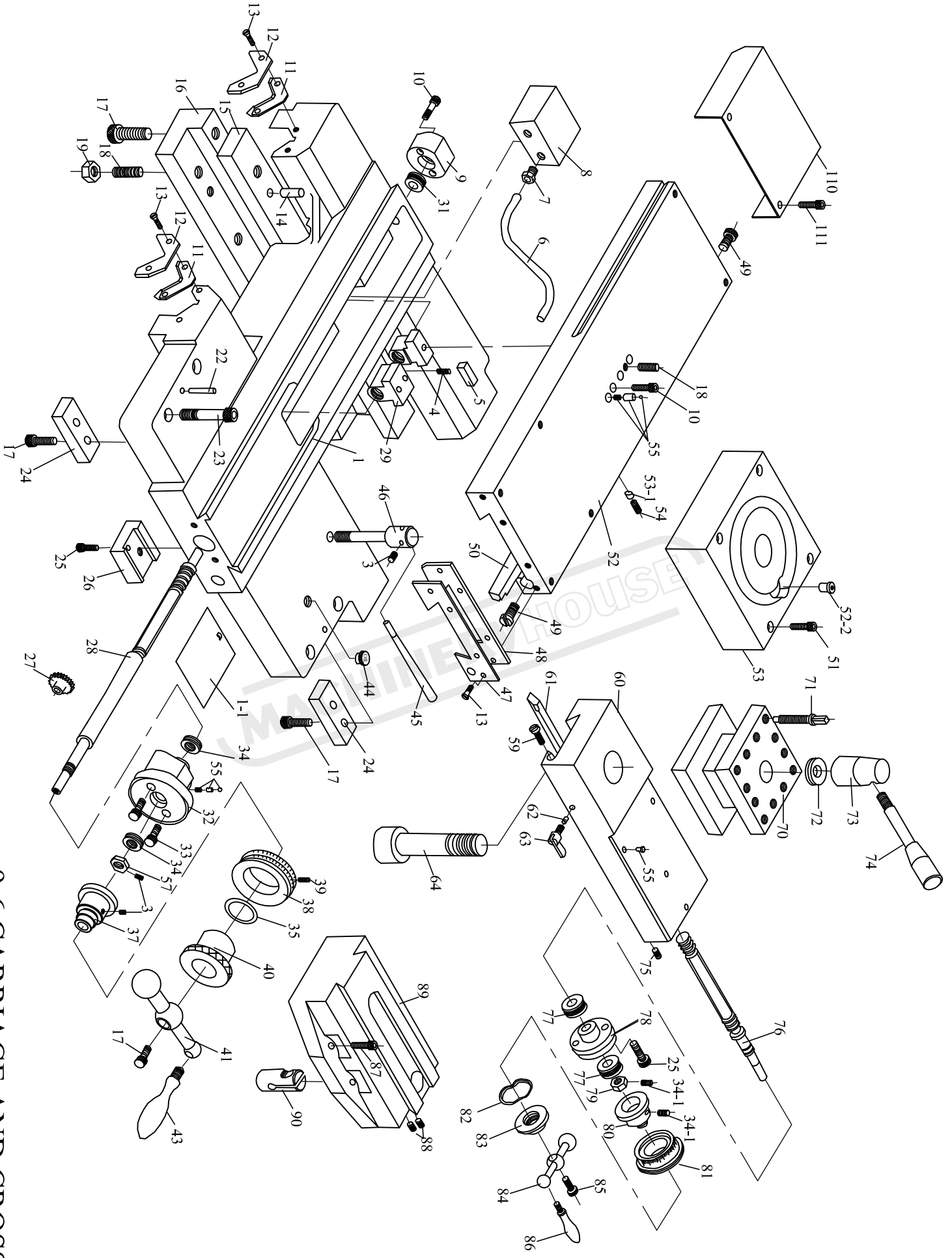

9-6 CARRIAGE AND CROSSFEED

CARRIAGE AND CROSSFEED ASSEMBLY

ITEM NO.	Part Name	Amt. Used	Model: 33" Part No.	Model: 37" Part No.	Model: 41" Part No.
1	Carriage	1	5006001	5006001	5006001
1-1	cover	1	5006001-001	5006001-001	5006001-001
2	Nut-crossfeed	1	5006002	5006002	5006002
3	Set screw , M6xP1.0x6.0L	5	91120606	91120606	91120606
4	Spring , 1x5x25L	1	4006004	4006004	4006004
5	Shim-crossfeed nut	1	3006005	3006005	3006005
6	Pipe-lubrication oil	1			
7	Nut-copper	1			
8	Conveyor-oil	1	3006008	3006008	3006008
9	Cap-crossfeed screw	1	5006009	5006009	5006009
10	Hexagon socket screw, M6xP1.0x25L	5	91110625	91110625	91110625
11	Wiper-rear	4	5006011	5006011	5006011
12	Case-wiper , rear	4	5006012	5006012	5006012
13	Screw-cross-recessed, M4xP0.7x10L	12			
14	Pin	2			
15	Gib	1	5006015	5006015	5006015
16	Holder-gib	1	5006016	5006016	5006016
17	Hexagon socket screw, M8xP1.25x20L	8	91110820	91110820	91110820
18	Set screw, M8xP1.25x25L	5	91120825	91120825	91120825
19	Nut , M8xP1.25	5			
22	Pin-taper , 6 # 75L	2	4006022	4006022	4006022
23	Hexagon socket screw, M10xP1.5x70L	4	91111070	91111070	91111070
24	Gib-left-front	2	5006024	5006024	5006024
25	Hexagon socket screw , M6xP1.0x16L	3	91110616	91110616	91110616
26	Clamp-carriage	1	5006026	5006026	5006026
27	Gear	1	5006027	5006027	5006027
28	Screw-crossfeed (5M/M , mm)		5006028	5006028	5006028
29	Nut M25xp5.0	1	5006029	5006029	5006029
31	Bearing thrust, 51101	2	91303001	91303001	91303001
32	Bracket	1	5006032	5006032	5006032
33	Bolt-hexa. Socket , M8xP1.25x40L	2	91110840	91110840	91110840
34	Bearing thrust, 51104	2	91303003	91303003	91303003
34-1	Set screw,	2			
35	Washer-wave type , 6210	1			
37	Clutch-dial	1	5006037	5006037	5006037
38	Dial-crossfeed (10M/M , left)	1	5006038	5006038	5006038
39	Set screw ,M6xP1.0x15L	2	91120615	91120615	91120615
40	Nut M35	1	5006040	5006040	5006040
41	Handle	1	5006041	5006041	5006041
43	Knob-handle	1	5006043	5006043	5006043
43-1	Screw-handle	1	3006043-001	3006043-001	3006043-001
43-2	Knob-handle	1	3006043-002	3006043-002	3006043-002
44	Plug-oil inlet	1	3006044	3006044	3006044

CARRIAGE AND CROSSFEED ASSEMBLY

ITEM NO.	Part Name	Amt. Used	Model: 33" Part No.	Model: 37" Part No.	Model: 41" Part No.
45	Lever	1	3006045	3006045	3006045
46	Screw-carriage clamp	1	3006046	4006046	4006046
47	Case-wiper	1	5006047	5006047	5006047
48	Wiper	1	5006048	5006048	5006048
49	Screw-adjusting	2	4006049	4006049	4006049
50	Gib	1	5006050	5006050	5006050
51	Bolt-hexa. Socket , M10xP1.5x40L	4	91111040	91111040	91111040
52	Cover-cross sliding	1	5006052	5006052	5006052
52-2	Plug	4	5006052-002	5006052-002	5006052-002
53	Bracket -cross slideing	1	5006053-001	5006053-002	5006053-003
53-1	Shoe-clamp	1	3006053	3006053	3006053
54	Set screw, M8xP1.25x20L	1	91120820	91120820	91120820
55	Ball-steel , 1/4"	4			
56	Square key , 5x5x15L	1	91610501	91610501	91610501
57	Shoe-Nut	1	3006057	3006057	3006057
59	Screw-gib	2	5006059	5006059	5006059
60	Compound rest	1	5006060	5006060	5006060
61	Gib-compound rest	1	5006061	5006061	5006061
62	Shoe-clamp	1	5006062	5006062	5006062
63	Screw-clamp	1			
64	Shaft-tool post	1	5006064	5006064	5006064
70	Tool post-square	1	5006070	5006070	5006070
71	Screw-square head	1	5006071	5006071	5006071
72	Bearing-thrust	1			
73	Knob-lever	1	5006073	5006073	5006073
74	Lever	1	5006074	5006074	5006074
75	Screw-gib, M8xP1.25x30L	1	5006075	5006075	5006075
76	Screw compound rest	1	5006076	5006076	5006076
77	Bearing thrust, 51102	2			
78	Seat-compound rest screw	1			
79	Nut	1			
80	Collar	1	5006080	5006080	5006080
81	Dial-compound rest	1	5006081	5006081	5006081
82	Washer-wave type	1			
83	Nut	1			
84	Handle	1	5006084	5006084	5006084
85	Hexagon socket screw, M6xP1.0x16L	1	91110616	91110616	91110616
86	Knob-handle	1	5006086	5006086	5006086
87	Hexagon socket screw, M12xP1.75x15L	4	91111215	91111215	91111215
88	Set screw, M8xP1.25x8L	2	91120808	91120808	91120808
89	Swivel	1			
90	Nut-compound rest screw	1	5006090	5006090	5006090
110	Dust proof cover	1	5006110	5006110	5006110
111	Hexagon socket screw, M5xP0.8x12L	2	91110512	91110512	91110512

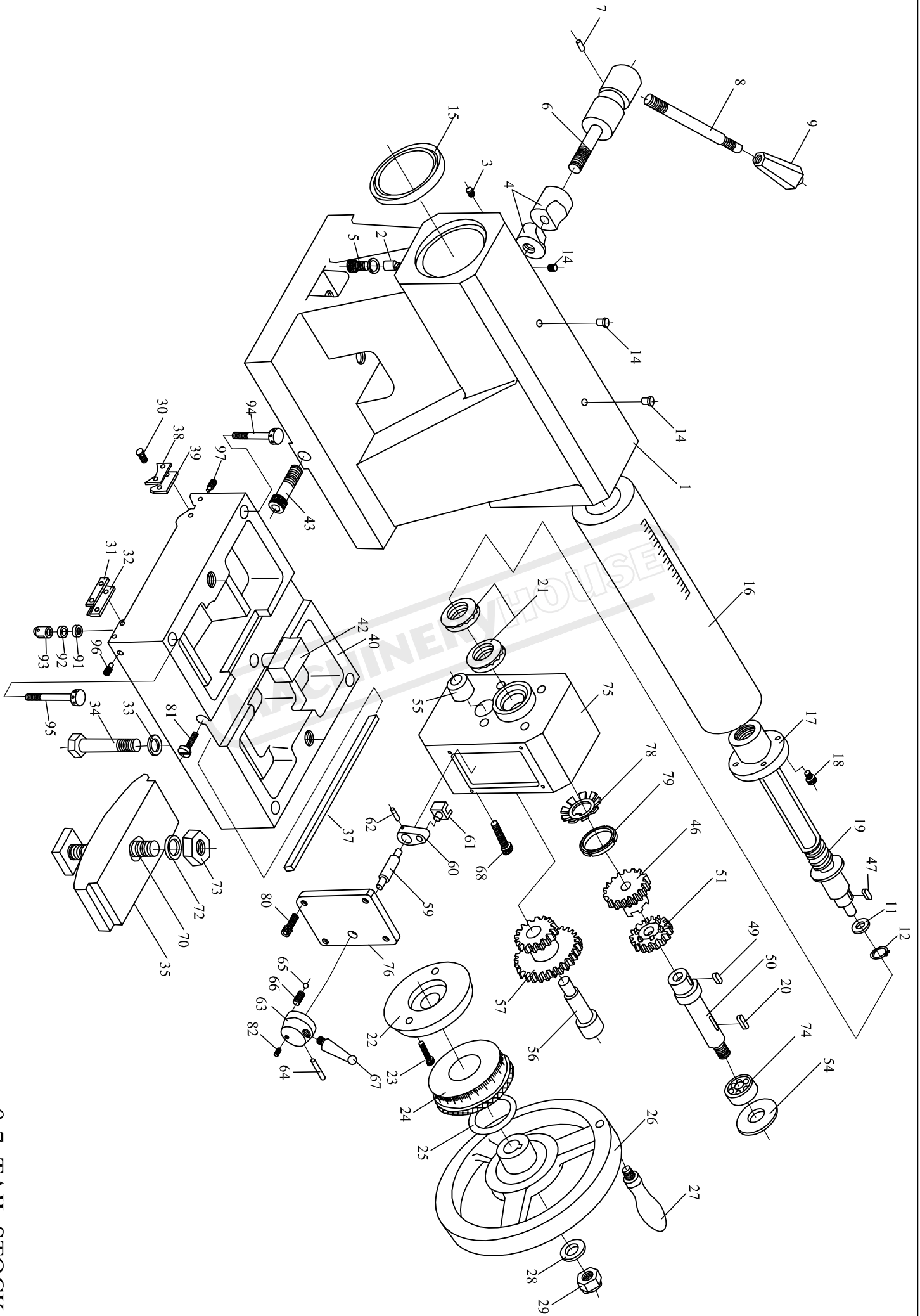

9-7 TAIL STOCK

TAILSTOCK ASSEMBLY

ITEM NO.	Part Name	Amt. Used	Model: 33" Part No.	Model: 37" Part No.	Model: 41" Part No.
1	Body-tailstock	1	5007001	5007001	5007001
2	Set key	1	5007002	5007002	5007002
3	Set screw, M6xP1.0x12L	1	91120612	91120612	91120612
4	Block-clamp	1	5007004	5007004	5007004
5	Hexagon socket screw, M8xP1.25x10L	1	91110810	91110810	91110810
6	Shaft-clamp spindle	1	5007006	5007006	5007006
7	Pin , 5x12	1			
8	Lever	1	3007008	3007008	3007008
9	Sleeve-lever	1	3007009	3007009	3007009
11	Washer	1	3507300	3507300	3507300
12	Snap ring S18	1	9171S018	9171S018	9171S018
14	Plug-oil , 1/4"	3			
15	Seal-oil , TC120X150X14	1			
16	Spindle-tang slot	1	5007016	5007016	5007016
17	Cap-spindle	1	5007017	5007017	5007017
18	Hexagon socket screw, M8xP1.25x16L	4	91110816	91110816	91110816
19	Screw-spindle feed (mm)	1	5007019	5007019	5007019
20	Key-square , 6x6x25	1	91610606	91610606	91610606
21	Bearing-thrust, 51205	2	91303006	91303006	91303006
22	Indicator	1	4007022	4007022	4007022
23	Hexagon socket screw, M5xP0.8x15L	2	91110515	91110515	91110515
24	Dial-feed	1	3507024-M01	3507024-M01	3507024-M01
25	Washer-wave type, WW-46	1			
26	Handwheel	1	3507026	3507026	3507026
27	Knob	1	3007027	3007027	3007027
28	Washer , W1/2"	1			
29	Nut , 1/2"-20UNF	1			
30	Screw-cross-recessed, M4xP0.7x10L	8			
31	Case-wiper	2	5007031	5007031	5007031
32	Wiper	2	5007032	5007032	5007032
33	Washer-flat , M12	2			
34	Bolt-clamp, M12xP1.75X75L	2	91111275	91111275	91111275
35	Clamp	2	5007035	5007035	5007035
36	Nut	1			
37	Strip	1	3507037	4007037	4007037
38	Case	2	5007038	5007038	5007038
39	Wiper	2	5007039	5007039	5007039
40	Bottom-tailstock	1	5007040-033	5007040-037	5007040-041
42	Blcok-adjusting	1	5007042	5007042	5007042
43	Hexagon socket screw, M10xP1.5x80L	2	91111080	91111080	91111080
46	Clutch shaft	1	4007046	4007046	4007046

TAILSTOCK ASSEMBLY

ITEM NO.	Part Name	Amt. Used	Model: 33" Part No.	Model: 37" Part No.	Model: 41" Part No.
47	Square key , 5x5x10L	1			
49	Square key , 5x5x25L	1			
50	Clutch shaft	1	5007050	5007050	5007050
51	Gear	1	4007051	4007051	4007051
54	Washer	1	5007054	5007054	5007054
55	Spacer	1	5007055	5007055	5007055
56	Idle shaft	1	5007056	5007056	5007056
57	Gear	1	4007057	4007057	4007057
59	Shaft	1	5007059	5007059	5007059
60	Shifting lever	1	4007060	4007060	4007060
61	Shifting fork	1	4007061	4007061	4007061
62	Spring pin , ϕ 4x25L	1			
63	Knob	1	3507063	3507063	3507063
64	Spring pin , ϕ 5x38L	1			
65	Ball steel , ϕ 1/4"	1	91820104	91820104	91820104
66	Spring , D6xd1x20L	1			
67	Lever	1	3007067	3007067	3007067
68	Hexagon socket screw, M8xP1.25x125L	4	911108125	911108125	911108125
70	Bolt clamp	2	4007070	4007070	4007070
72	Washer , W3/4	2			
73	Nut , W3/4-10NC	2			
74	Ball bearing , 6204	1			
75	Shifting box	1	5007075	5007075	5007075
76	Shifting cover	1	5007076	5007076	5007076
78	Wash W25	1			
79	Nut M25	1			
80	Hexagon socket screw, M5xP0.8x10L	4	91110510	91110510	91110510
81	Screw	1	3007081	3007081	3007081
82	Screw M8xP1.25X10L	1			
91	Set screw	4	4007091	4007091	4007091
92	stoper	4	4007092	4007092	4007092
93	turning nut	4	4007093	4007093	4007093
94	set bolt	2	5007094-033	5007094-037	5007094-041
95	set bolt	2	5007095-033	5007095-037	5007095-041
96	set bolt	2	5007096	5007096	5007096
97	set bolt	2	5007097	5007097	5007097